

RECOMMENDED PANEL MOUNTING

PANEL THICKNESS	X
0.75-1.25	19.2-19.3
1.25-2.00	19.3-19.4
2.00-3.00	19.5-19.6

SWITCH FUNCTION		
POS. 1	POS. 2	POS. 3
ON	NONE	OFF
1-1a	N/A	OPEN

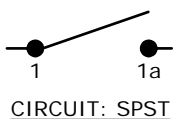

NOTES:

1. ALL DIMENSIONS IN MM [INCH]
2. GENERAL TOLERANCE: X.X=±0.4
X.XX=±0.25
3. TERM. NOS. FOR REF. ONLY
- ▲ 4. RATING: 15A@125VAC UL, CUL
8A@250VAC UL, CUL
6A@250VAC VDE
5. LAMP VOLTAGE: 3VDC
6. MATERIAL:
CONTACT SURFACE: GOLD OVER SILVER PLATE
7. ELECTRICAL LIFE: 10,000 CYCLES
8. CONTACT RESISTANCE: <20 MILLI-OHMS INITIAL
9. DIELECTRIC STRENGTH: >1,500V AC 1 MIN
10. ▲ DENOTES CRITICAL PARAMETER.

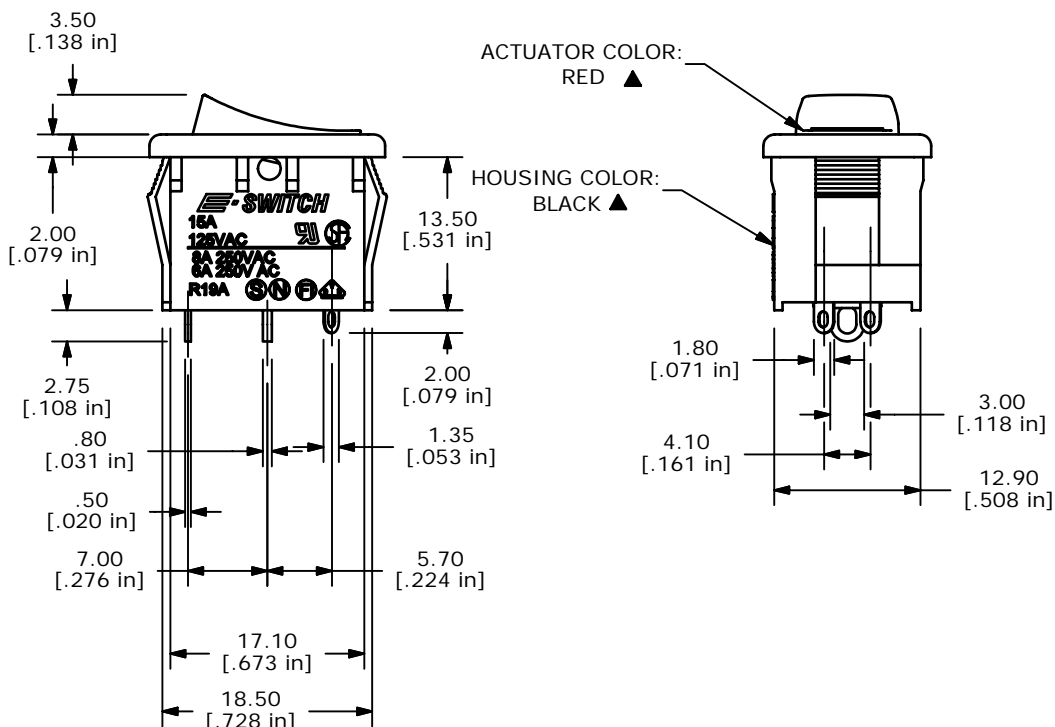
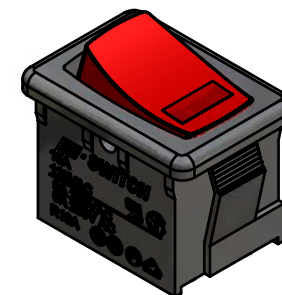
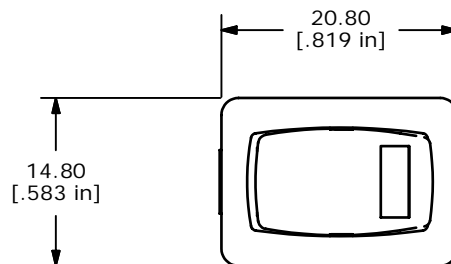

REV	PCR NO	DESCRIPTION	DATE	BY
C	15833	EDIT NOTES	3/1/06	PH
B	15705	REMOVE TERMINAL INFO FROM NOTES	1/25/06	PH
A	15688	RELEASED FOR PRODUCTION	1/18/06	PH



TITLE R1966ABLKREDESRED (w/GOLD CONTACTS)				
SCALE	DATE	DR	DWG	REV
1.5:1	1/18/2006	PH	M300010	C

THE INFORMATION CONTAINED IN THIS DOCUMENT IS PROPRIETARY TO E-SWITCH AND IS NOT TO BE COPIED OR TRANSFERRED