

RECOMMENDED PANEL MOUNTING

PANEL THICKNESS	X
0.75-1.25	19.2-19.3
1.25-2.00	19.3-19.4
2.00-3.00	19.5-19.6

SWITCH FUNCTION		
POS. 1	POS. 2	POS. 3
ON	NONE	OFF
1-1a	N/A	OPEN

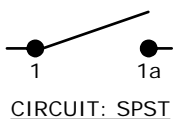

NOTES:

- ALL DIMENSIONS IN MM [INCH]
- GENERAL TOLERANCE: X.X=±0.4  
X.XX=±0.25
- TERM. NOS. FOR REF. ONLY
- RATING: 15A@125VAC  
8A@250VAC
- LAMP VOLTAGE: 3VDC ▲
- MATERIAL:  
CONTACT SURFACE: GOLD OVER SILVER PLATE
- ELECTRICAL LIFE: 10,000 CYCLES
- CONTACT RESISTANCE: <20 MILLI-OHMS INITIAL
- DIELECTRIC STRENGTH: >1,500V AC 1 MIN
- ▲ DENOTES CRITICAL PARAMETER.

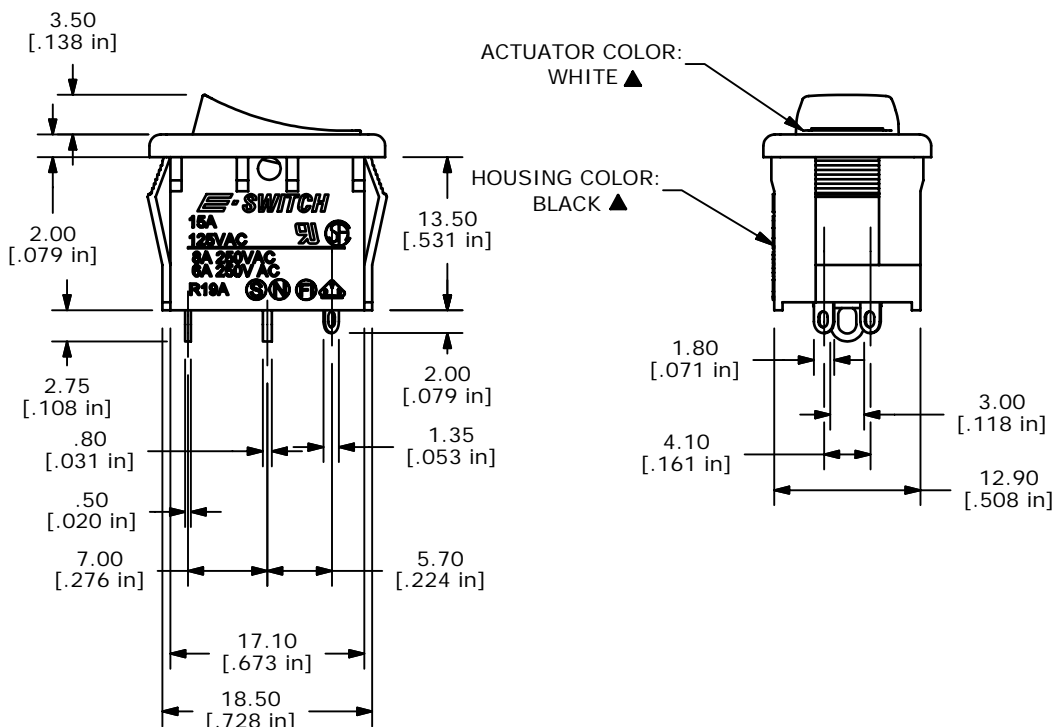
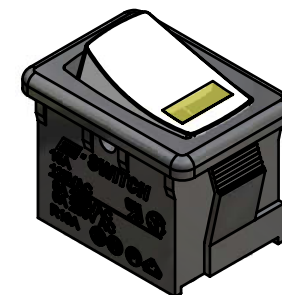
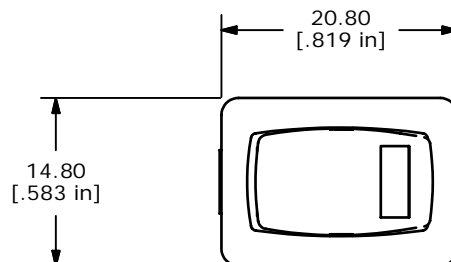

**E-SWITCH®**

REV	PCR NO	DESCRIPTION	DATE	BY
B	15705	REMOVED TERMINAL INFO FROM NOTES	1/25/06	PH
A	15628	RELEASED FOR PRODUCTION	1/3/06	PH

TITLE R1966ABLKWHITESYEL (w/GOLD CONTACTS)				
SCALE	DATE	DR	DWG	REV
1.5:1	1/3/2006	PH	M300009	B

THE INFORMATION CONTAINED IN THIS DOCUMENT IS PROPRIETARY TO E-SWITCH AND IS NOT TO BE COPIED OR TRANSFERRED