

RECOMMENDED PANEL MOUNTING

PANEL THICKNESS	X± 0.05
0.75-1.25	29.65
1.25-2.00	30.15
2.00-3.00	30.50

HOUSING COLOR: BLACK

LENS COLOR: GREEN

ROCKER COLOR: BLACK

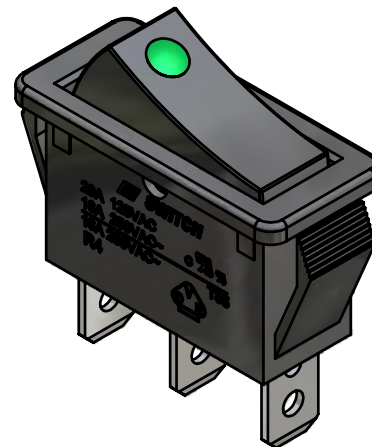

SWITCH FUNCTION		
POS. 1	POS. 2	POS. 3
ON	N/A	OFF
1-1a	NONE	OPEN

NOTES:

- ALL DIMENSIONS IN MM [INCH]
- GENERAL TOLERANCE: X.X=±0.4
X.XX=±0.25
- TERM. NOS. FOR REF. ONLY
- RATING: 20A 125VAC, 16A 250VAC UL APPROVED
16A 250VAC VDE APPROVED
- MECHANICAL LIFE: > 30,000 CYCLES
- ELECTRICAL LIFE: < 20mOHMS (INITIAL)
- DIELECTRIC STRENGTH: > 1500V 1 min
- LAMP VOLTAGE: 250VAC NEON
- OPERATING TEMPERATURE: TERMINAL SIDE: -20°C to 85°C
ROCKER SIDE: -20°C to 55°C
- FLAMABILITY: UL94 V-2
- ▲ DENOTES CRITICAL PARAMETER.
- 2002/95/EC (ROHS) COMPLIANT

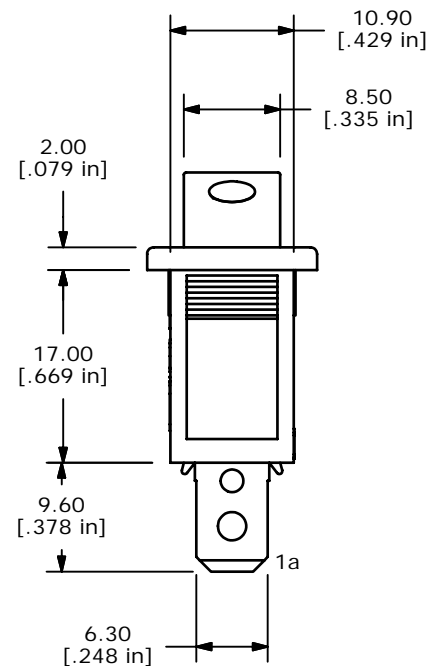
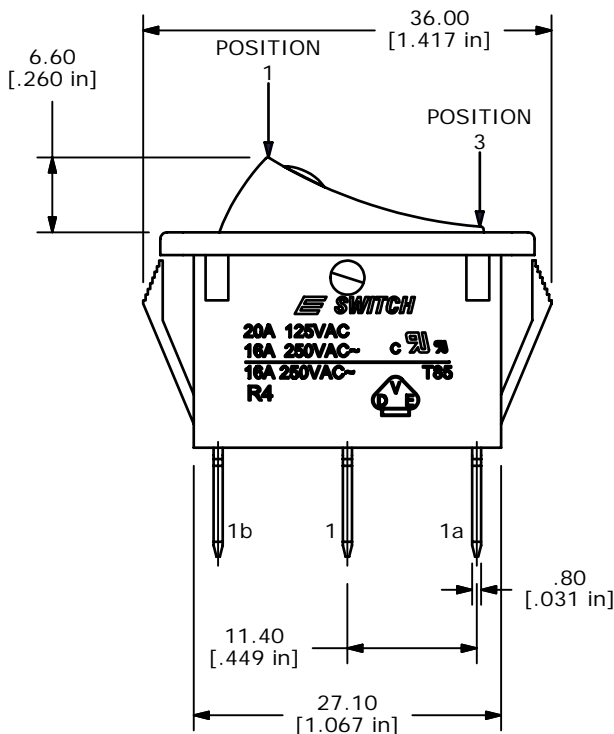
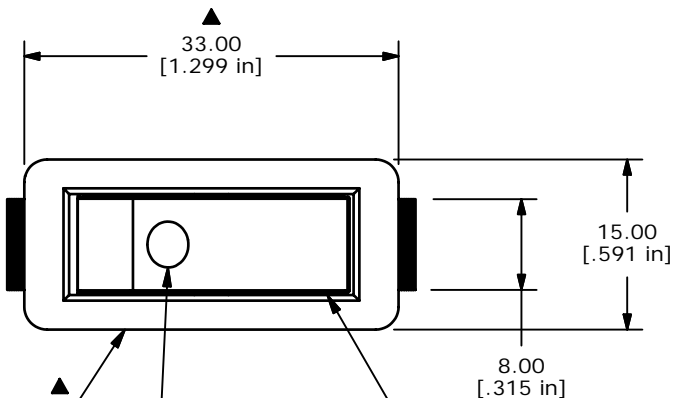

REV	PCR NO	DESCRIPTION	DATE	BY
E	16131	UPDATE LENS COLOR IN ISO VIEW	6/12/06	CT
D	16014	UPDATE TO CURRENT STANDARDS	5/9/06	CT
C	15832	REVISE AND REDRAWN	3/1/06	PH

THE INFORMATION CONTAINED IN THIS DOCUMENT IS PROPRIETARY TO E-SWITCH AND IS NOT TO BE COPIED OR TRANSFERRED



TITLE R4BBLKBLKGRNEF2

SCALE 1.5:1	DATE 3/1/2006	DR --	DWG M040123	REV E
-------------	---------------	-------	-------------	-------