

RECOMMENDED PANEL MOUNTING

PANEL THICKNESS	X± 0.05
0.75-1.25	29.65
1.25-2.00	30.15
2.00-3.00	30.50

SWITCH FUNCTION		
POS. 1	POS. 2	POS. 3
ON	N/A	ON
1-1a	NONE	1-1b

- NOTES:
- ALL DIMENSIONS IN MM [INCH]
 - GENERAL TOLERANCE: X.X=± 0.4
X.XX=± 0.25
 - TERM. NOS. FOR REF. ONLY
 - RATING: 20A 125VAC, 16A 250VAC UL APPROVED
16A 250VAC VDE APPROVED
 - MECHANICAL LIFE: > 30,000 CYCLES
 - ELECTRICAL LIFE: < 20mOHMS (INITIAL)
 - DIELECTRIC STRENGTH: > 1500V 1 min
 - OPERATING TEMPERATURE: TERMINAL SIDE: -20°C to 85°C
ROCKER SIDE: -20°C to 55°C
 - FLAMABILITY: UL94 V-2
 - ▲ DENOTES CRITICAL PARAMETER
 - 2002/95/EC (ROHS) COMPLIANT

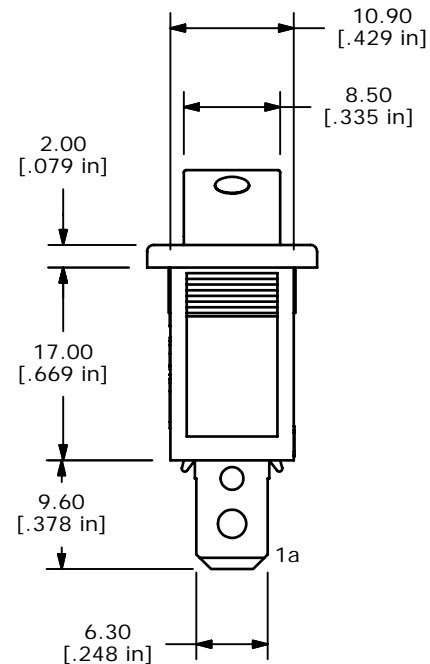
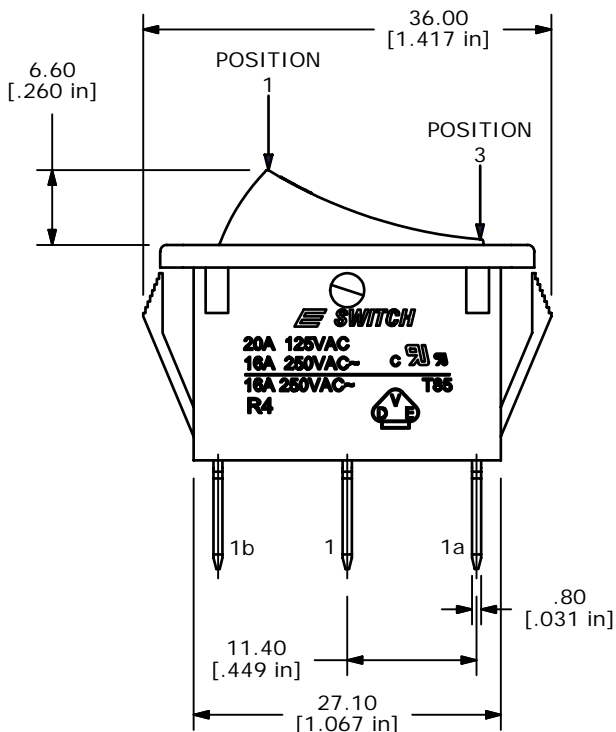
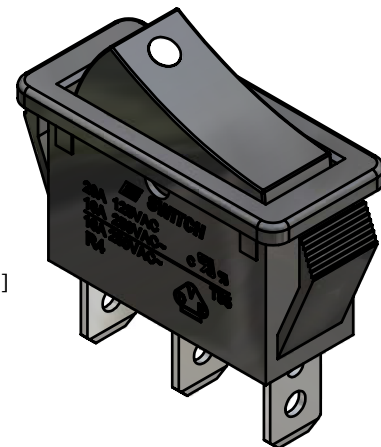
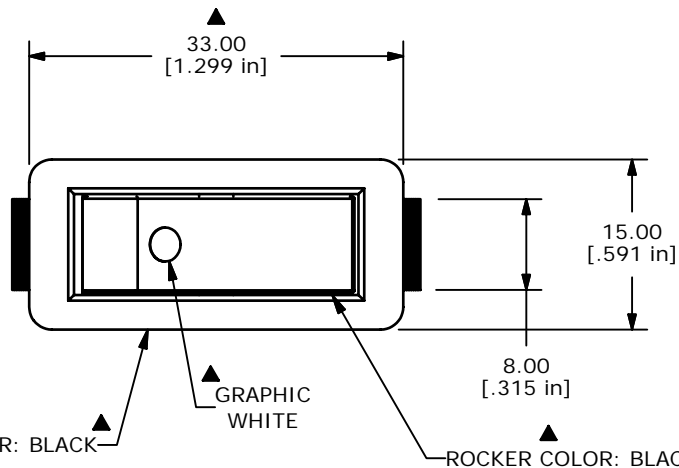
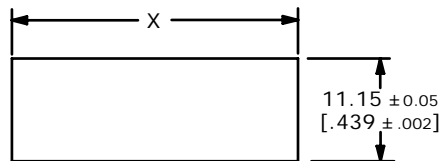

REV	PCR NO	DESCRIPTION	DATE	BY
E	16014	UPDATE TO CURRENT STANDARDS	5/9/06	CT
D	15832	REVISE AND REDRAWN	3/1/06	PH

TITLE R4BLKBLKAF0				
SCALE 1.5:1	DATE 3/1/2006	DR --	DWG M040122	REV E

THE INFORMATION CONTAINED IN THIS DOCUMENT IS PROPRIETARY TO E-SWITCH AND IS NOT TO BE COPIED OR TRANSFERRED