

*SUGGESTED PANEL CUTOUT*

PANEL THICKNESS	X
0.75-1.25 (.030-.049)	19.2 (.756)
1.25-2.0 (.049-.079)	19.4 (.764)

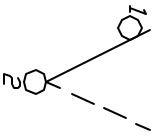

*CIRCUIT: SPST*

*CONTACT CONFIGURATION*

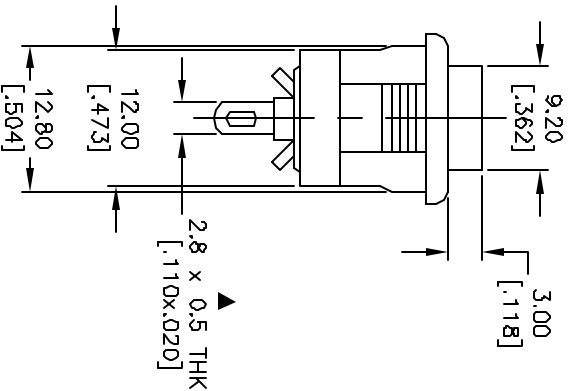
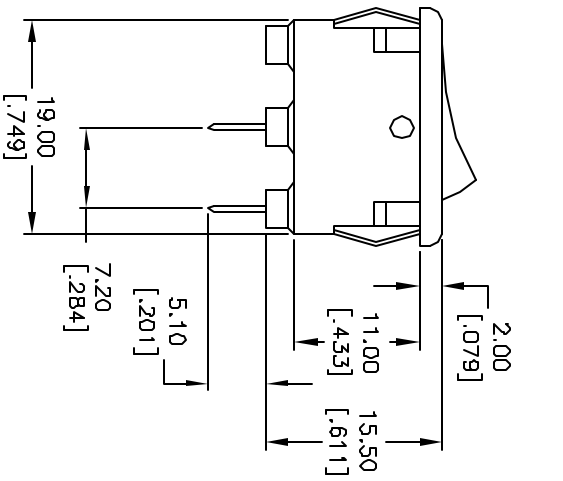
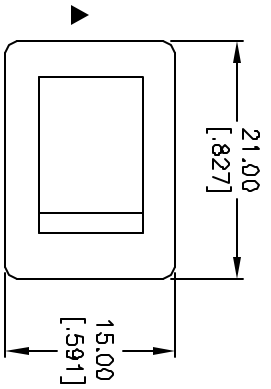

NOTES:

1. ALL DIMENSIONS IN MM
2. GENERAL TOLERANCE: X.X=±0.4  
X:XX=±0.25
3. TERM. NOS. FOR REFERENCE ONLY.
4. RATING: 10A 125VAC/5A 250VAC
5. CONTACTS: SILVER PLATED COPPER ALLOY
6. ▲ DENOTES CRITICAL PARAMETER.

C	13296	REMOVE TABLE, UPDATE STANDARDS	7/16/03	AR
B	10945	ADD MARKING FOR "1"	9/12/00	GIG
REV.	ECN No.	DESCRIPTION	DATE	CHKD

TITLE		RA1066ASX		
SCALE	DATE	DR	DWG	REV
1.5:1	10/3/96	MM	P300200	C



THE INFORMATION CONTAINED IN THIS DOCUMENT IS PROPRIETARY TO E-SWITCH AND IS NOT TO BE COPIED OR TRANSFERRED