

RECOMMEND P.C.B. PANEL MOUNTING

PANEL THICKNESS	X
0.75-1.25 (.030-.049)	19.2 (.756)
1.25-2.0 (.049-.079)	19.4 (.764)

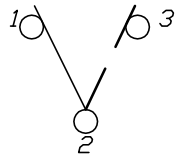

CIRCUIT: SPDT



CONTACT CONFIGURATION

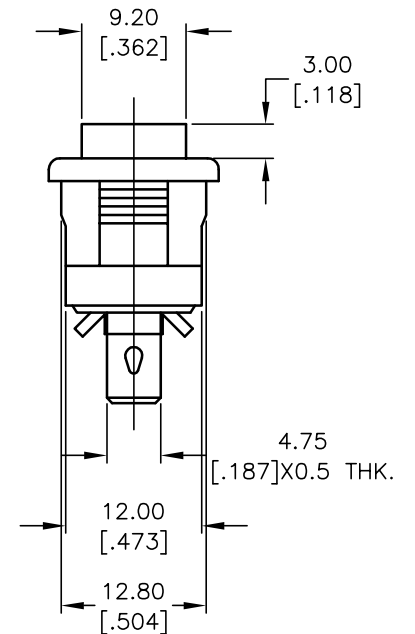
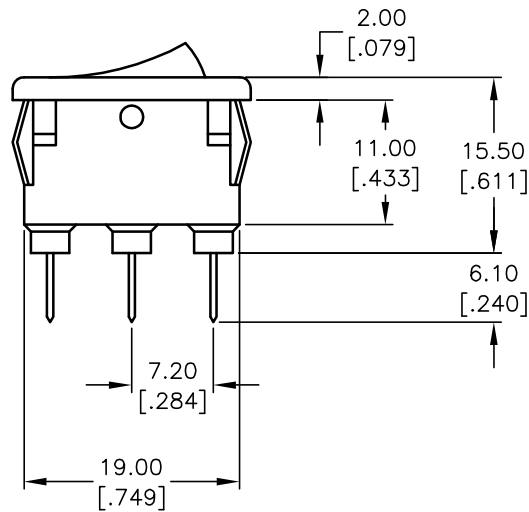

NOTES:

1. ALL DIMENSIONS IN MM
2. GENERAL TOLERANCE: X.X=±0.4  
X.XX=±0.25
3. TERM. NOS. FOR REFERENCE ONLY.
4. RATING: 10A 125VAC/5A 250VAC
- ▲ 5. CONTACTS: SILVER PLATED COPPER ALLOY
6. ▲ DENOTES CRITICAL PARAMETER.

**E-SWITCH®**

TITLE		RA1066CFK			
SCALE	DATE	DR	DWG	REV	
1.5:1	1/30/04	AR	P300109	B	

B	14346	CORRECT CIRCUIT	9/24/04	AR
A	13741	RELEASED FOR PRODUCTION	1/30/04	AR
REV.	ECN No.	DESCRIPTION	DATE	CHKD

THE INFORMATION CONTAINED IN THIS DOCUMENT IS PROPRIETARY TO E-SWITCH AND IS NOT TO BE COPIED OR TRANSFERRED