

RECOMMENDED PANEL MOUNTING

NOT TO SCALE

| PANEL THICKNESS | X |
|-----------------------|-------------|
| 0.75-1.25 (.030-.049) | 19.2 (.756) |
| 1.25-2.0 (.049-.079) | 19.4 (.764) |

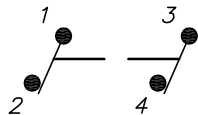

CIRCUIT: DPST

NOTES:

1. ALL DIMENSIONS IN MM [INCH]
2. GENERAL TOLERANCE: X.X=±0.4
X.XX=±0.25
3. TERM. NOS. FOR REF. ONLY
4. RATING: AC 125V 12A, AC 250V 8A
5. MECHANICAL LIFE: 15,000 cycles
6. ELECTRICAL LIFE: 10,000 cycles
7. CONTACT RESISTANCE: 10mILLI-Ohms
8. INSULATION RESISTANCE: >1000Mega-Ohms
9. DIELECTRIC STRENGTH: 1,500 Volts for 1min.
3,000 Volts between poles
10. OPERATING TEMP: -30°C to 85°C
- ▲11. HOUSING COLOR: BLACK
- ▲12. ACTUATOR COLOR: WHITE
13. ▲ DENTOES CRITICAL PARAMETER.

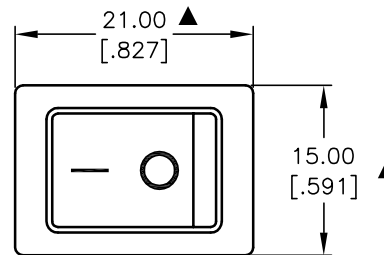

MARKING "F"

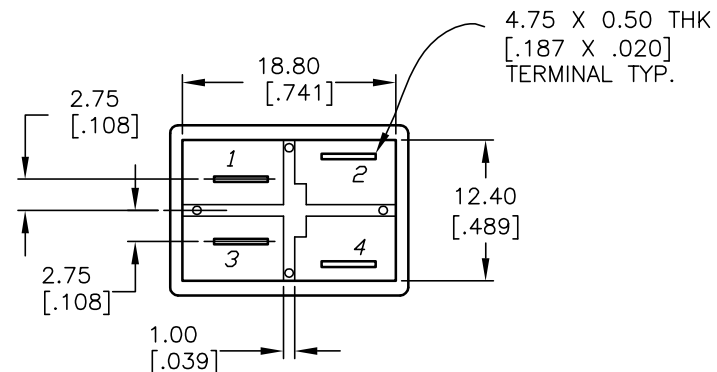
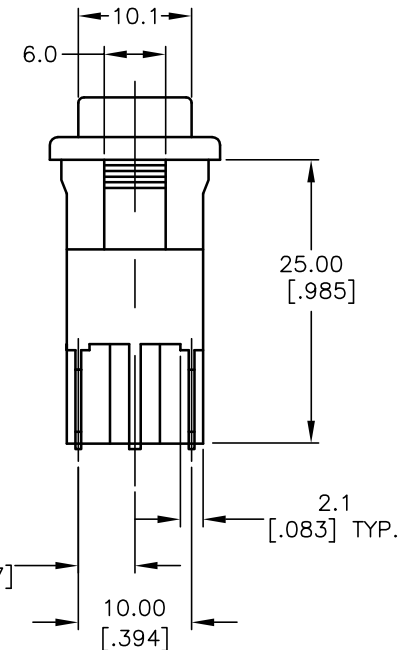
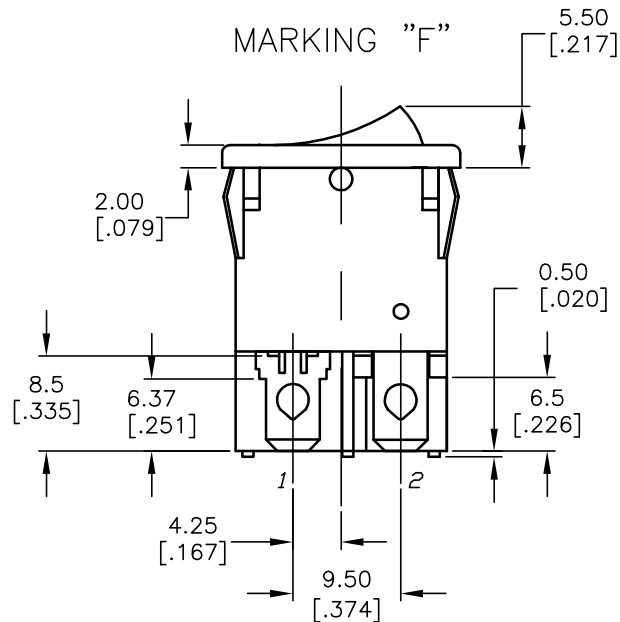

E-SWITCH®

| | | | | | | | | | |
|-------|-------|------|---------|----|------------------|-----|---------|-----|---|
| TITLE | | | | | RC1083BBLKWHTFFO | | | | |
| SCALE | 1.5:1 | DATE | 8/26/03 | DR | AR | DWG | P301509 | REV | A |

THE INFORMATION CONTAINED IN THIS DOCUMENT IS PROPRIETARY TO E-SWITCH AND IS NOT TO BE COPIED OR TRANSFERRED