

THIS DRAWING IS UNPUBLISHED. RELEASED FOR PUBLICATION  
 © COPYRIGHT BY TYCO ELECTRONICS CORPORATION. ALL RIGHTS RESERVED.

LOC		DIST		REVISIONS			
P	LTR	DESCRIPTION	DATE	DWN	APVD		
AD	0	A1	ECO-07-021997	18SEP07	MB	MW	

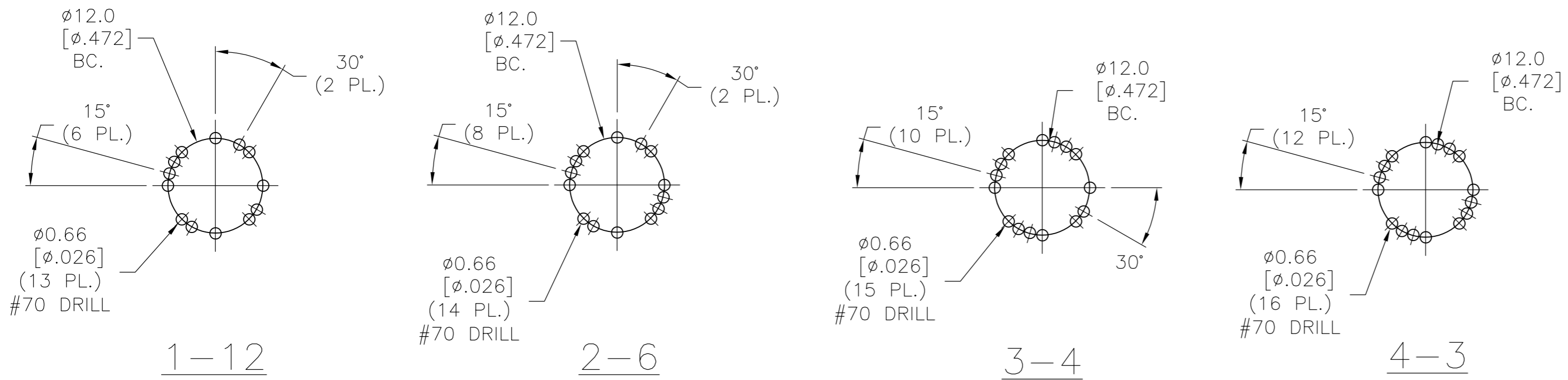
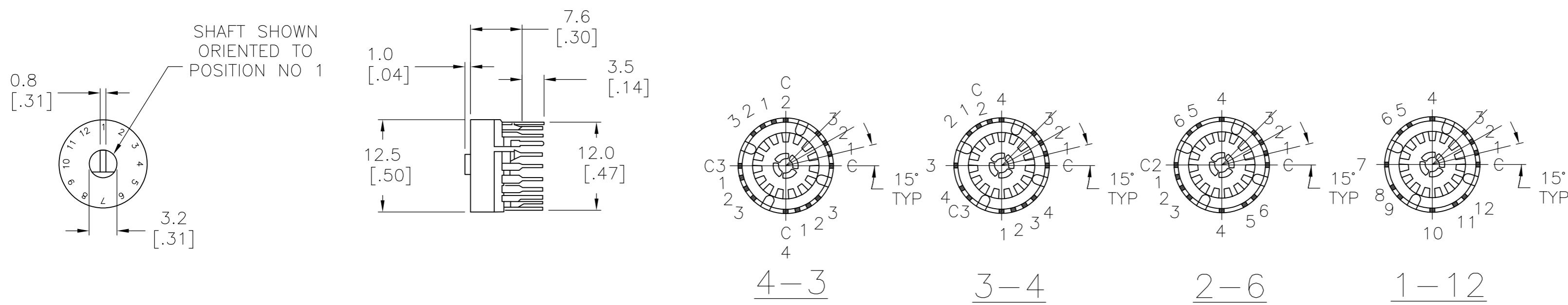

NOTES:

1. TERMINAL NUMBERS ARE FOR REFERENCE ONLY AND DO NOT APPEAR ON SWITCHES.
2. ALL MATERIALS AND FINISHES SHALL COMPLY WITH EU DIRECTIVE 2002/95/EC OF 27JAN2003 (ROHS).

SPECIFICATIONS	
RATING	.4VA MAX. @ 20VDC, OR PEAK AC
TIMING	BREAK BEFORE MAKE
INITIAL CONTACT RESISTANCE	30 MILLIOHMS MAX
INSULATION RESISTANCE	10,000 MEGOHMS MIN
DIELECTRIC WITHSTANDING VOLTAGE	1,000 VRMS AT SEA LEVEL
DURABILITY	10,000 CYCLES @ .4VA RESISTIVE
	30,000 CYCLES @ .1μA 12VDC RESISTIVE
OPERATING FORCE	14 INCH OUNCES
OPERATING TEMPERATURE	-20°C TO +70°C
STORAGE TEMPERATURE	-20°C TO +70°C

MATERIALS		
COMPONENT NAME	BASE MATERIAL	FINISH
BASE	EPOXY	
FIXED CONTACT	BRASS	GOLD OVER NICKEL
MOVEABLE CONTACT	COPPER ALLOY	GOLD OVER NICKEL
TERMINALS	BRASS	TIN OVER NICKEL

POSITIONS	POLES	ALCO P/N	TE P/N
3 FIXED.	4	MRJB304	1825536-4
4 FIXED.	3	MRJB404	1825536-3
6 FIXED.	2	MRJB604	1825536-2
12 CONTINUOUS ROTATION.	1	MRJB1204	1825536-1

THIS DRAWING IS A CONTROLLED DOCUMENT.		DWN	100CT79	Tyco Electronics Corporation Harrisburg, PA 17105-3608
DIMENSIONS: mm [INCHES]		CHK	100CT79	
TOLERANCES UNLESS OTHERWISE SPECIFIED:		APVD	-	
0 PLC ± - 1 PLC ± - 2 PLC ± - 3 PLC ± - 4 PLC ± - ANGLES ± -		PRODUCT SPEC	-	
MATERIAL	FINISH	WEIGHT	-	NAME
SEE SPECIFICATIONS	SEE SPECIFICATIONS	CUSTOMER DRAWING	-	ROTARY SWITCH 12 POSITION-30° DETENT.
		SCALE	2:1	SIZE
		SHEET	1 OF 1	CAGE CODE
		REV	A1	DRAWING NO
				A2 00779 C=1825536

1825536