

RECOMMENDED HOLE LAYOUT

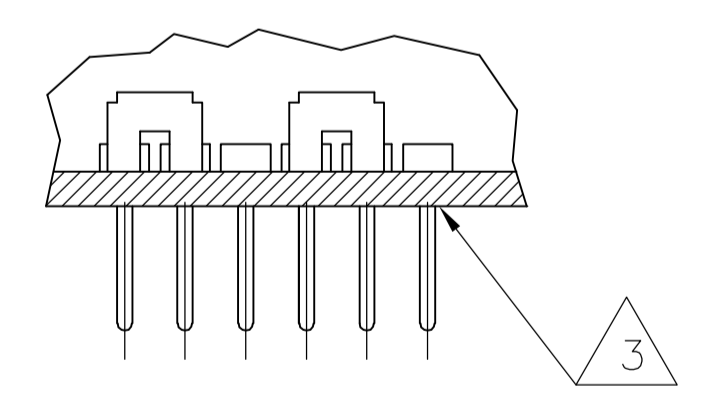
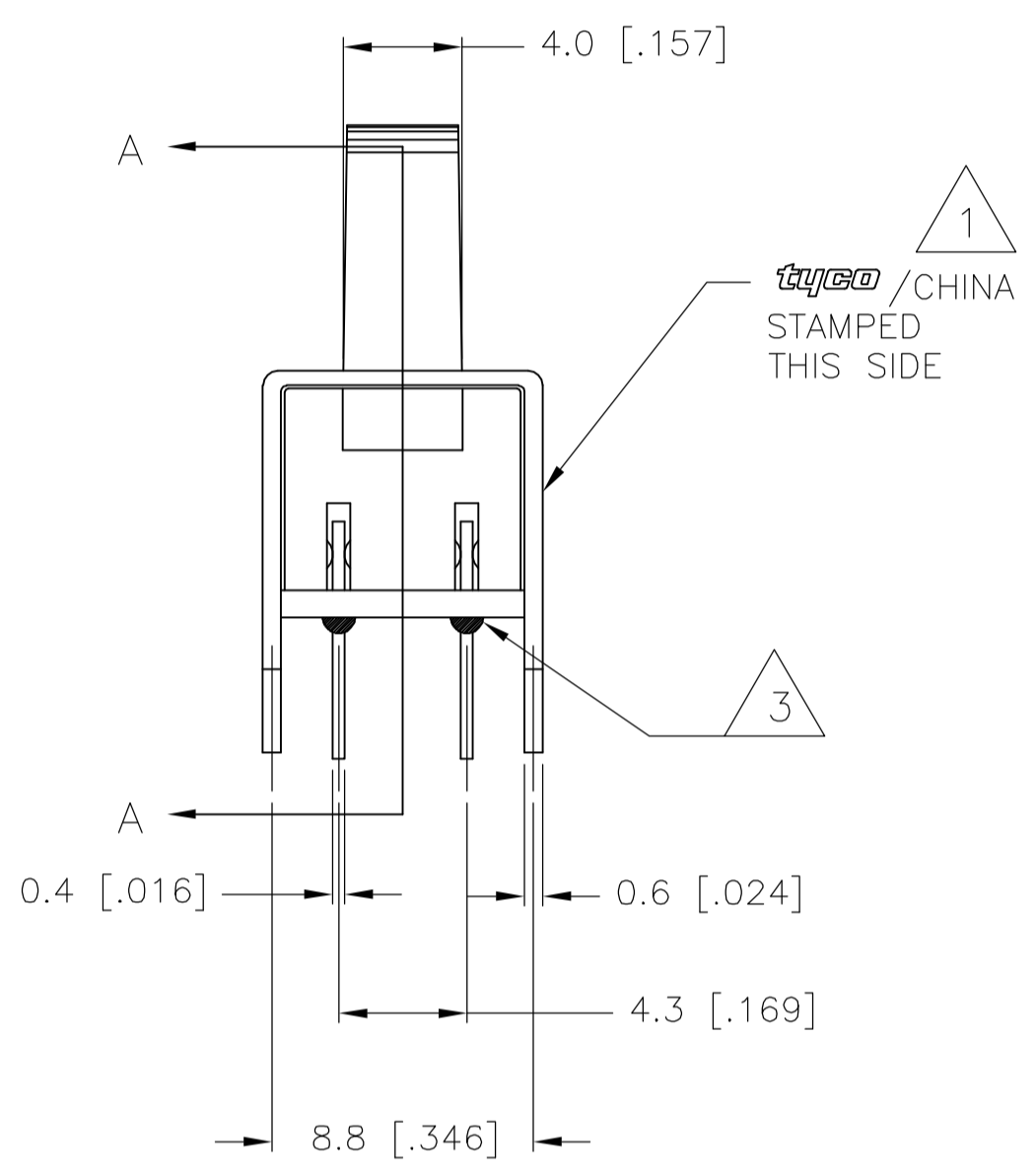

SECTION A-A

SPECIFICATIONS
 MAKE-BEFORE-BREAK

MATERIALS:
 ACTUATOR- POM, UL94HB BLACK
 TERMINAL BOARD- PHENOLIC LAMINATED SHEET, UL94HB, NATURAL
 FRAME- STEEL, NICKEL PLATE
 TERMINAL/FIXED CONTACT- COPPER ALLOY, GOLD OR SILVER OVER NICKEL PLATE
 MOVING CONTACT- COPPER ALLOY, GOLD OR SILVER OVER NICKEL PLATE
 DETENT BALL- STEEL
 COIL SPRING- GALVANIZED SPRING WIRE
 SEAL- EPOXY

ELECTRICAL:
 CONTACT RATING- .4VA@20VDC OR PEAK AC (GOLD); 300mA@125V AC (SILVER)
 INITIAL CONTACT RESISTANCE- 30 milliohm max.
 FINAL CONTACT RESISTANCE- 100 milliohm max. (AFTER TEST)
 INSULATION RESISTANCE- 1,000 Megohms min.
 DIELECTRIC STRENGTH- 500V RMS@SEA LEVEL
 LIFE EXPECTANCY- 15,000 CYCLES MIN.

MECHANICAL:
 ACTUATION FORCE- 600+/-300 GRAMS
 TRAVEL- 2.0 +/-0.50 (0.079 +/-0.020)

ENVIRONMENTAL:
 OPERATING TEMPERATURE- -20 TO +85 DEGREES C
 STORAGE TEMPERATURE- -40 TO +100 DEGREES C
 RESISTANCE TO SOLDER HEAT PER 109-202, CONDITION B
 SOLDERABILITY PER EIA-364-52, CLASS 2, CATEGORY 1, 95% MIN COVERAGE

NOTES:

- MARK PER 202-37 SPECIFICATION, *tyco*/CHINA MINIMUM REQUIREMENT
- ALL MATERIALS AND FINISHES SHALL COMPLY WITH EU DIRECTIVE 2002/95/EC OF 27JAN2003 (ROHS)
- ANTI SOLDER WICK SEAL AT TERMINAL TO BOARD INTERFACE
- ALL PERFORMANCE TESTING WAS DONE IN ACCORDANCE TO TYCO SPECIFICATION 102-2469

1825264-2	MSS4200G04	GOLD	1 TO 2 4 TO 5 7 TO 8 10 TO 11	2 TO 3 5 TO 6 8 TO 9 11 TO 12
1825264-1	MSS420004	SILVER	1 TO 2 4 TO 5 7 TO 8 10 TO 11	2 TO 3 5 TO 6 8 TO 9 11 TO 12
TYCO PART NO.	T&B PART NO.	PLATING		

TERMINALS CONNECTED WHEN SLIDE IS IN POSITION SHOWN.

THIS DRAWING IS A CONTROLLED DOCUMENT.		DWN: R BROWN 21DEC05	tyco Electronics	Tyco Electronics Corporation Harrisburg, Pa 17105-3608	
DIMENSIONS: mm		CHK: M SARVER 21DEC05		NAME: SLIDE SWITCH, MSS 4200 SERIES	
TOLERANCES UNLESS OTHERWISE SPECIFIED:		APP'D: M SARVER 21DEC05	PRODUCT SPEC: -		
0 PLC ± -		APPLICATION SPEC: -			
1 PLC ± 0.3 [0.12]		SIZE: A1			
2 PLC ± -		CAGE CODE: 00779			
3 PLC ± -		DRAWING NO: 1825264			
4 PLC ± -		RESTRICTED TO: -			
ANGLES ± -		WEIGHT: -			
FINISH: -		CUSTOMER DRAWING			
		SCALE: 4:1		SHEET 1 OF 1	