

THIS DRAWING IS UNPUBLISHED. RELEASED FOR PUBLICATION  
 © COPYRIGHT BY TYCO ELECTRONICS CORPORATION. ALL RIGHTS RESERVED.

LOC	DIST	REVISIONS			
P	LTR	DESCRIPTION	DATE	DWN	APVD
AD	00	A	ECO 05 006799	03MAY06	BSV SM

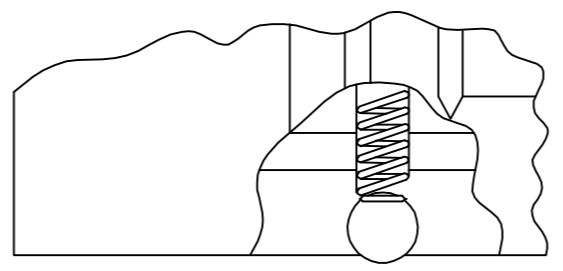
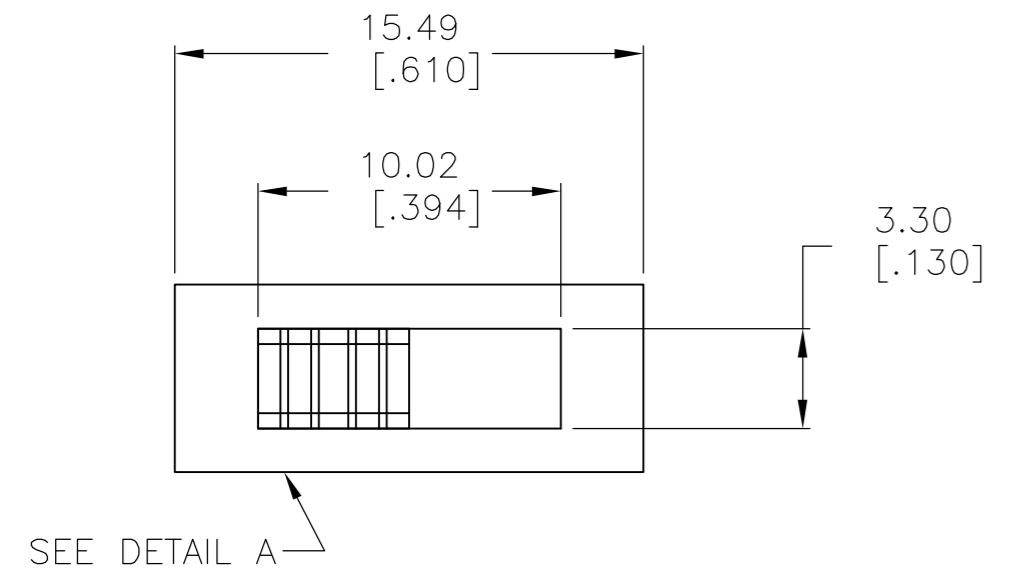

DETAIL A

SPECIFICATIONS:  
 MAKE-BEFORE-BREAK

MATERIALS:  
 FRAME: STEEL, ZINC PLATE  
 ACTUATOR: POM UL94HB, BLACK  
 FIXED CONTACT/TERMINAL: COPPER ALLOY, SILVER OVER NICKEL PLATE  
 MOVING CONTACT: COPPER ALLOY, SILVER CLAD  
 COIL SPRING: TEMPERED STEEL WIRE  
 BALL- TEMPERED CARBON STEEL  
 TERMINAL BOARD: PHENOLIC, UL94HB  
 TERMINAL SEAL: EPOXY

ELECTRICAL:  
 CONTACT RATING: 250 MILLIAMPS@125V AC  
 CONTACT RESISTANCE: 30 MILLIOHMS MAX (INITIAL), 60 MILLIOHMS AFTER TEST  
 INSULATION RESISTANCE: 500 MEGOHMS MIN AT 500V DC  
 DIELECTRIC STRENGTH: 500 VAC RMS AT SEA LEVEL  
 LIFE EXPECTANCY: 10,000 CYCLES MIN. NO LOAD

MECHANICAL:  
 ACTUATION FORCE: 250-100 GRAMS  
 TRAVEL: 2.49 [.098]

ENVIRONMENTAL:  
 OPERATING TEMPERATURE: -10° C TO +60° C  
 STORAGE TEMPERATURE: -10° C TO +60° C  
 RESISTANCE TO SOLDER HEAT: 260° C FOR 10 SEC PER 109-202, COND. B  
 SOLDERABILITY: PER EIA-364-56A, PROCEDURE 3, COND. B

- NOTES:  
 1. ALL MATERIALS AND FINISHES SHALL COMPLY WITH EU DIRECTIVE 2002/95/EC OF 27JAN2003 (ROHS)  
 2. ALL PERFORMANCE SPECIFICATIONS WERE TESTED IN ACCORDANCE WITH JIS-C-5441 UNLESS OTHERWISE STATED.

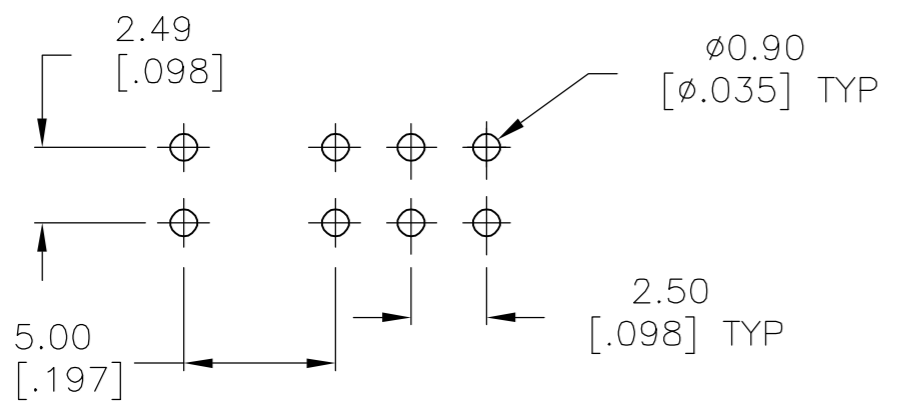
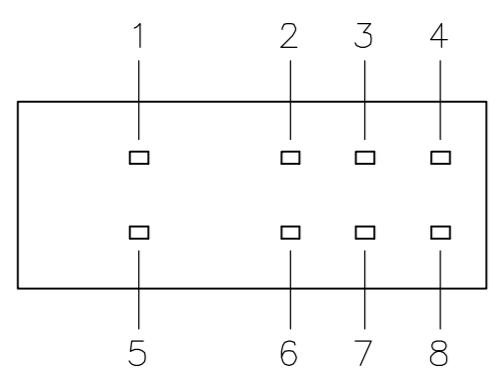
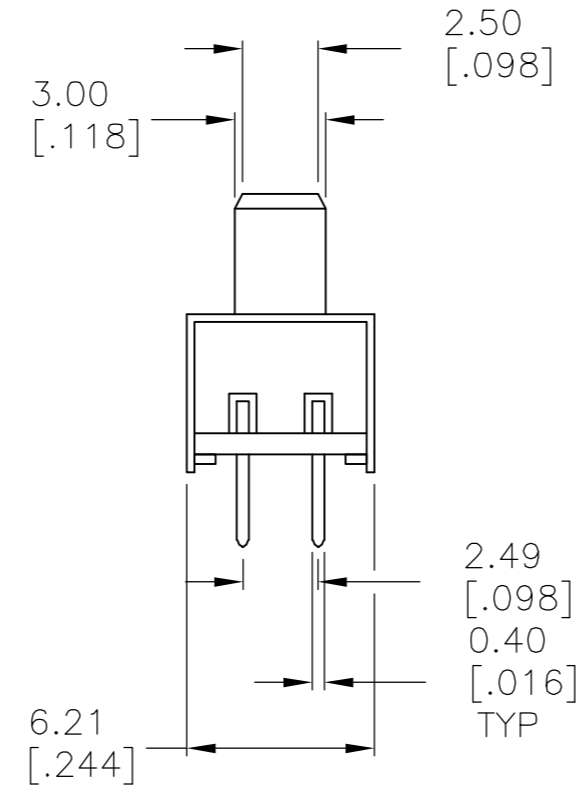
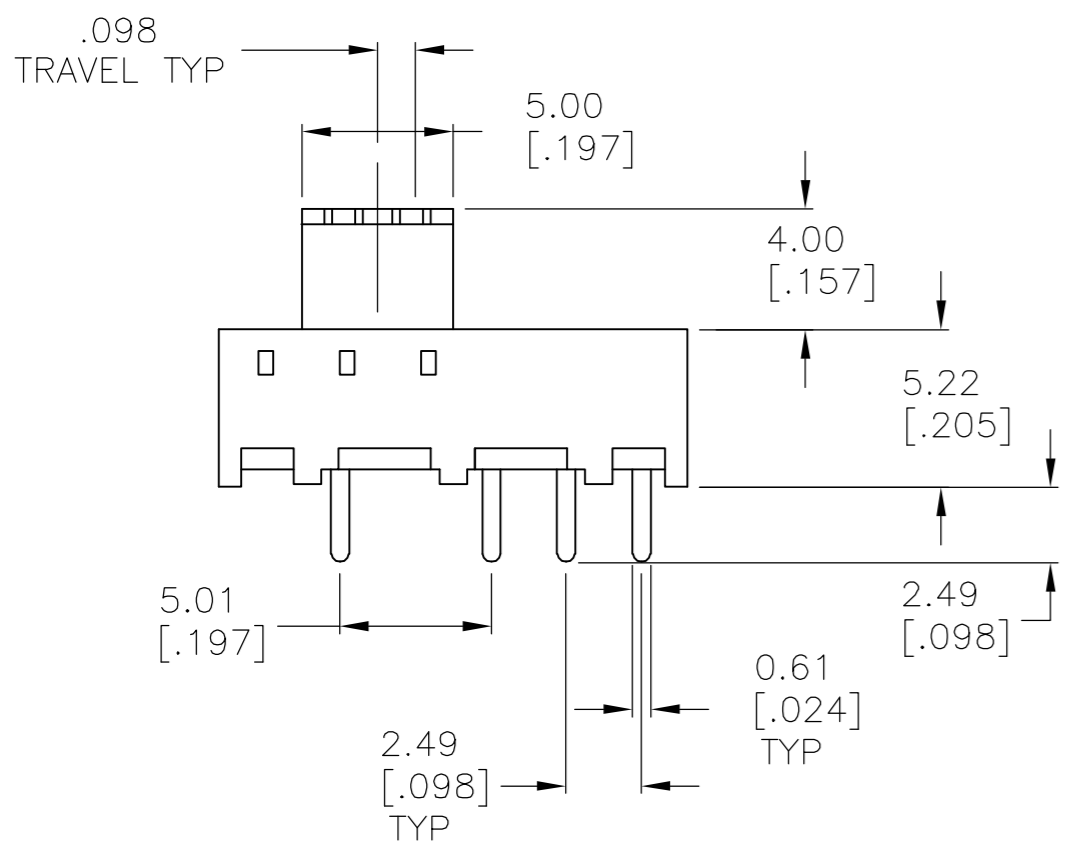

RECOMENDED HOLE LAYOUT  
 TOLERANCE ±.002 UNLESS OTHERWISE NOTED

1-2 5-6	2-3 6-7	2-4 6-8		DP3T	STS2300PC04	1825164-1
			BOTTOM VIEW	FUNCTION	T&B PART NUMBER	TYCO PART NUMBER
FUNCTION DIAGRAM						

THIS DRAWING IS A CONTROLLED DOCUMENT.		DWN B.S.VISWESWARA	18MAR05			Tyco Electronics Corporation Harrisburg, Pa 17105-3608	
DIMENSIONS: mm [INCHES]		CHK M.S.SARVER	APVD -	NAME SLIDE SWITCH (DP3T) STS2300PC SERIES			
TOLERANCES UNLESS OTHERWISE SPECIFIED: 0 PLC ± - 1 PLC ± - 2 PLC ± - 3 PLC ± .010 4 PLC ± - ANGLES ± 1°		PRODUCT SPEC -	APPLICATION SPEC -	SIZE A2	CAGE CODE 00779	DRAWING NO C=1825164	RESTRICTED TO -
MATERIAL SEE NOTES		FINISH SEE NOTES		WEIGHT -	SCALE 4:1	SHEET 1 OF 1	REV A
CUSTOMER DRAWING							

1825164