

RECOMMEND P.C.B LAYOUT

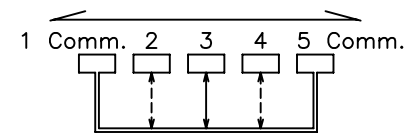
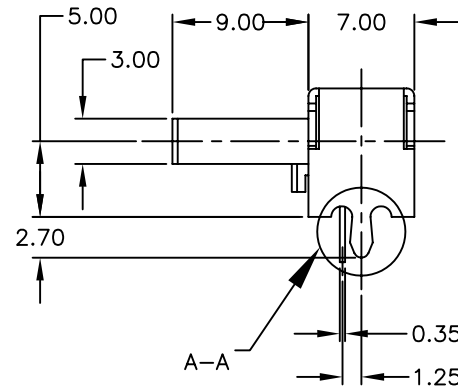
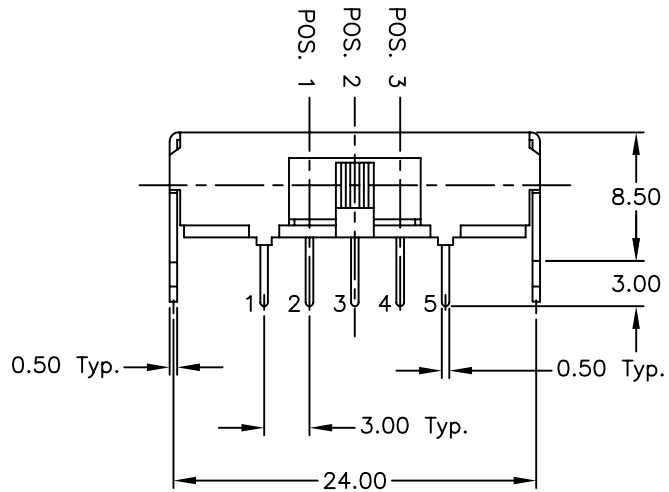

CIRCUIT:SP3T  
CONTACT CONFIGURATION

SWITCH FUNCTION		
POS. 1	POS. 2	POS. 3
1,5-2	1,5-3	1,5-4

1,5=Comm.

NOTES:

1. ALL DIMENSIONS IN MM
2. GENERAL TOLERANCE: 0.0=±0.4  
0.00=±0.25
3. RATING: DC 30V, 0.1A
4. TRAVEL: 3.0mm

REV.	ECN No.	DESCRIPTION	DATE	CHKD
B	14958	CHANGED TABLE	5/27/05	JB
A	10530	RELEASED FOR PRODUCTION	2/15/00	MM

THE INFORMATION CONTAINED IN THIS DOCUMENT IS PROPRIETARY TO E-SWITCH AND IS NOT TO BE COPIED OR TRANSFERRED

<b>E-SWITCH®</b>				
TITLE EG 1307				
SCALE 2:1	DATE 2/15/00	DR MM	DWG P040056	REV B