

RECOMMENDED BOARD LAYOUT

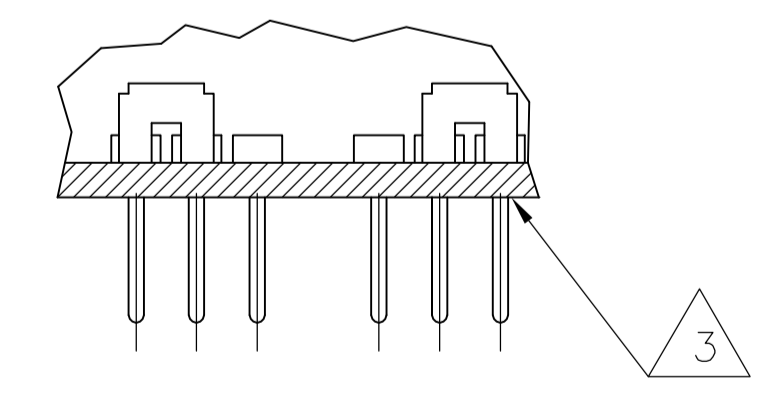
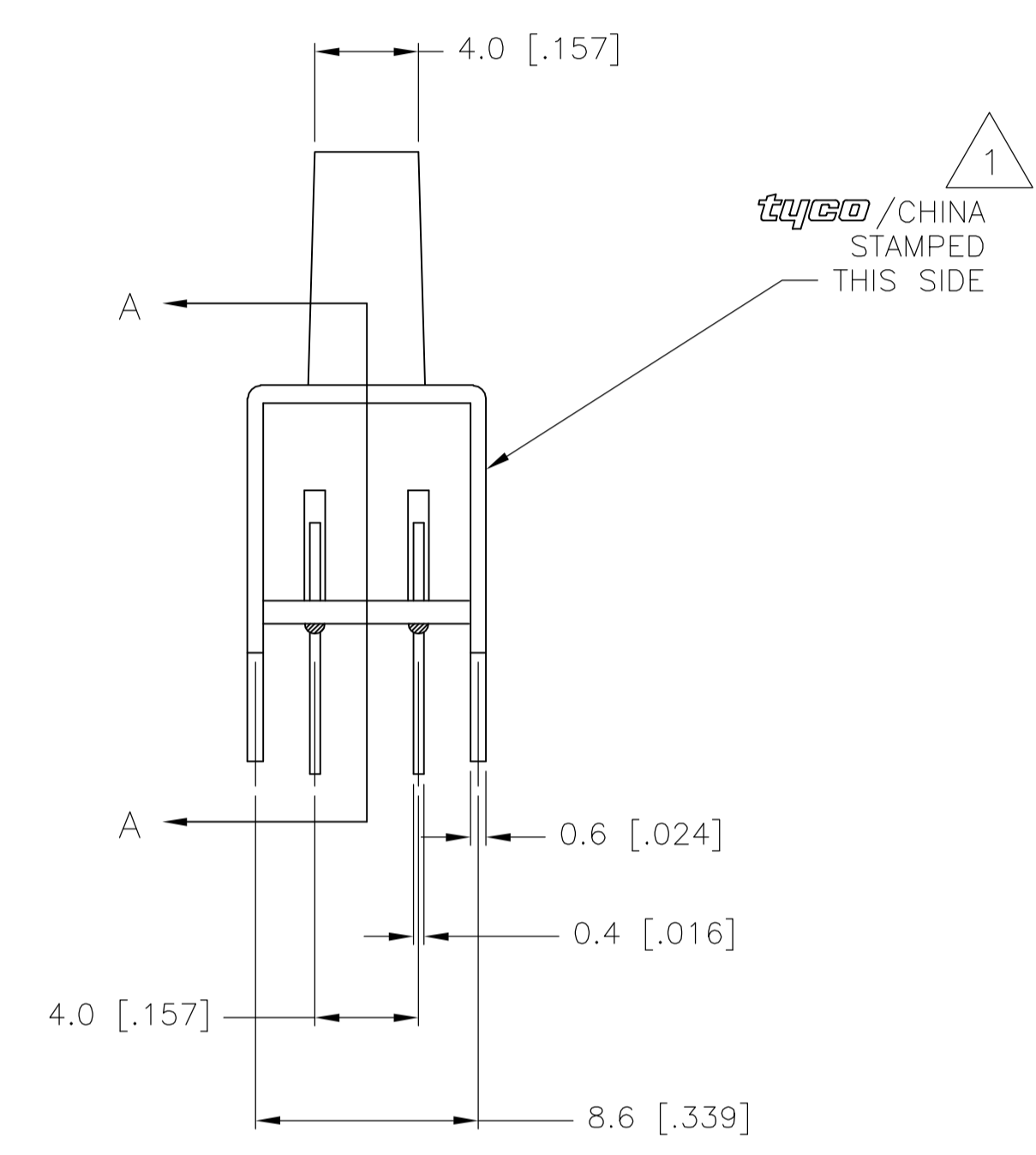

SECTION A-A

SPECIFICATIONS
 MAKE-BEFORE-BREAK

MATERIALS:
 ACTUATOR- POM, UL94HB BLACK
 TERMINAL BOARD- PHENOLIC LAMINATED SHEET, UL94HB, NATURAL
 FRAME- STEEL, NICKEL PLATE
 TERMINAL/FIXED CONTACT- COPPER ALLOY, GOLD OR SILVER OVER NICKEL PLATE
 MOVING CONTACT- COPPER ALLOY, GOLD OR SILVER OVER NICKEL PLATE
 DETENT BALL- STEEL
 COIL SPRING- GALVANIZED SPRING WIRE
 SEAL- EPOXY

ELECTRICAL:
 CONTACT RATING- .4VA@20VDC OR PEAK AC (GOLD); 300mA@125V AC (SILVER)
 INITIAL CONTACT RESISTANCE- 30 milliohm max.
 FINAL CONTACT RESISTANCE- 100 milliohm max. (AFTER TEST)
 INSULATION RESISTANCE- 1,000 Megohms min.
 DIELECTRIC STRENGTH- 500V RMS@SEA LEVEL
 LIFE EXPECTANCY- 15,000 CYCLES MIN.

MECHANICAL:
 ACTUATION FORCE- 600+/-300 GRAMS
 TRAVEL- 2.0 +/-0.50 (.079 +/-0.020)

ENVIRONMENTAL:
 OPERATING TEMPERATURE- -20 TO +85 DEGREES C
 STORAGE TEMPERATURE- -40 TO +100 DEGREES C
 RESISTANCE TO SOLDER HEAT PER 109-202, CONDITION B
 SOLDERABILITY PER EIA-364-52, CLASS 2, CATEGORY 1, 95% MIN COVERAGE

NOTES:

- MARK PER 202-37 SPECIFICATION, *tyco*/CHINA MINIMUM REQUIREMENT
- ALL MATERIALS AND FINISHES SHALL COMPLY WITH EU DIRECTIVE 2002/95/EC OF 27JAN2003 (ROHS)
- ANTI SOLDER WICK SEAL AT TERMINAL TO BOARD INTERFACE
- ALL PERFORMANCE TESTING WAS DONE IN ACCORDANCE TO TYCO SPECIFICATION 102-2469

-	MSS4335G04	GOLD	1 TO 2 5 TO 6 9 TO 10 13 TO 14	2 TO 3 6 TO 7 10 TO 11 14 TO 15	2 TO 4 6 TO 8 10 TO 12 14 TO 16
1825269-1	MSS433504	SILVER	1 TO 2 5 TO 6 9 TO 10 13 TO 14	2 TO 3 6 TO 7 10 TO 11 14 TO 15	2 TO 4 6 TO 8 10 TO 12 14 TO 16
TYCO PART NO.	T&B PART NO.	PLATING			

TERMINALS CONNECTED WHEN SLIDE IS IN POSITION SHOWN.

THIS DRAWING IS A CONTROLLED DOCUMENT.		DWN R BROWN	21DEC05	 Tyco Electronics Corporation Harrisburg, Pa 17105-3608
DIMENSIONS: mm		CHK M SARVER	21DEC05	
TOLERANCES UNLESS OTHERWISE SPECIFIED: 0 PLC ± - 1 PLC ± 0.3 [.012] 2 PLC ± - 3 PLC ± - 4 PLC ± - ANGLES ± -		APVD M SARVER	21DEC05	NAME SLIDE SWITCH, MSS 4335 SERIES
MATERIAL		WEIGHT	SIZE A1	CAGE CODE 00779
FINISH		RESTRICTED TO	DRAWING NO 1825269	
CUSTOMER DRAWING		SCALE 4:1	SHEET 1 OF 1	REV A