

RECOMMENDED P.C.B. LAYOUT
SCALE 3:1

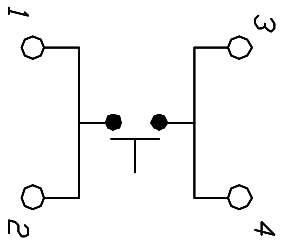

CIRCUIT: SPST

NOTES:

1. ALL DIMENSIONS IN MM [INCH]
2. GENERAL TOLERANCE: X.X=±0.4
X.XX=±0.25
3. TERM. NOS. FOR REFERENCE ONLY.
4. RATINGS: 12VDC, 50mA
5. OPERATING FORCE: 250±50gf
6. TRAVEL: 0.25±0.1mm
7. CONTACT RESISTANCE: 100 MILLI Ω Max.
8. DIELECTRIC STRENGTH: 250V RMS min.
9. INSULATION RESISTANCE: 100 Mega Ω min.
10. ELECTRICAL LIFE: 100,000 CYCLES min.
11. DESIGNATE MAJOR FEATURE:

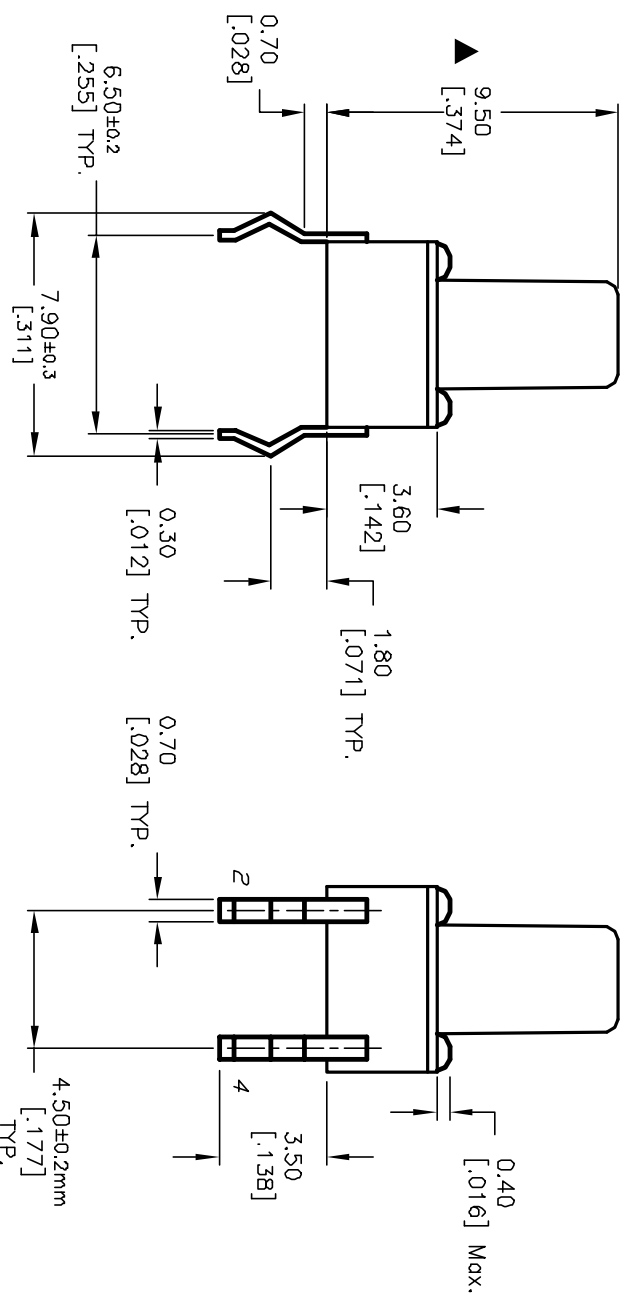

E-SWITCH®

REV. A		RELEASED FOR PRODUCTION		TITLE		SCALE		DATE		DR		DWG		REV	
11621		DESCRIPTION		TL1105B F250 Q		4:1		8/22/01		CJB		D310043		A	
ECN No.		DATE		CHKD		DATE		DATE		CJB		D310043		A	
<p>THE INFORMATION CONTAINED IN THIS DOCUMENT IS PROPRIETARY TO E-SWITCH AND IS NOT TO BE COPIED OR TRANSFERRED</p>															