

RECOMMENDED P.C.B. LAYOUT

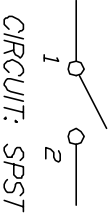

NOTES:

1. ALL DIMENSIONS IN MM
2. GENERAL TOLERANCE: X.X=±0.4
X.XX=±0.25
3. TERM. NOS. FOR REF. ONLY
4. RATING: 50mA, @12V DC
5. TRAVEL: 0.25±0.1mm
6. OPERATING FORCE: 100±50gf
7. CONTACT RESISTANCE: 100 milliohms Max.
8. ELECTRICAL LIFE: 100,000 CYCLES MIN.
9. ▲ DESIGNATE MAJOR FEATURE
10. ACTUATOR COLOR: BROWN
11. HOUSING COLOR: BLACK

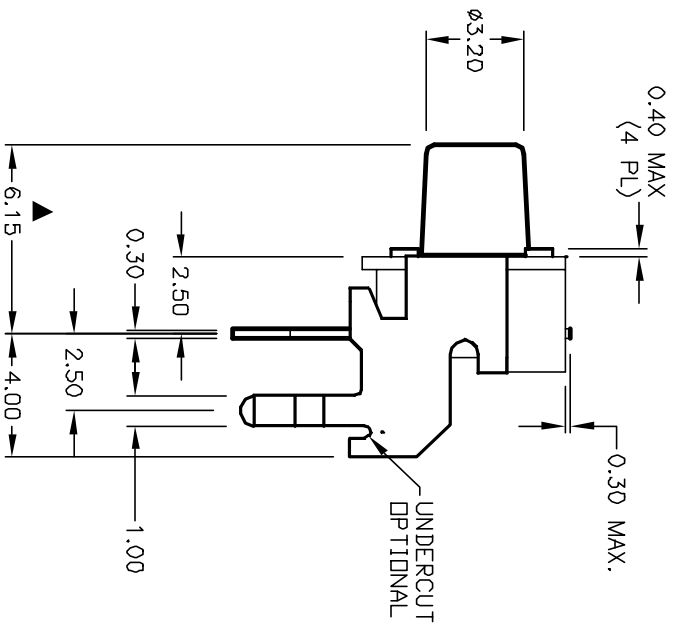
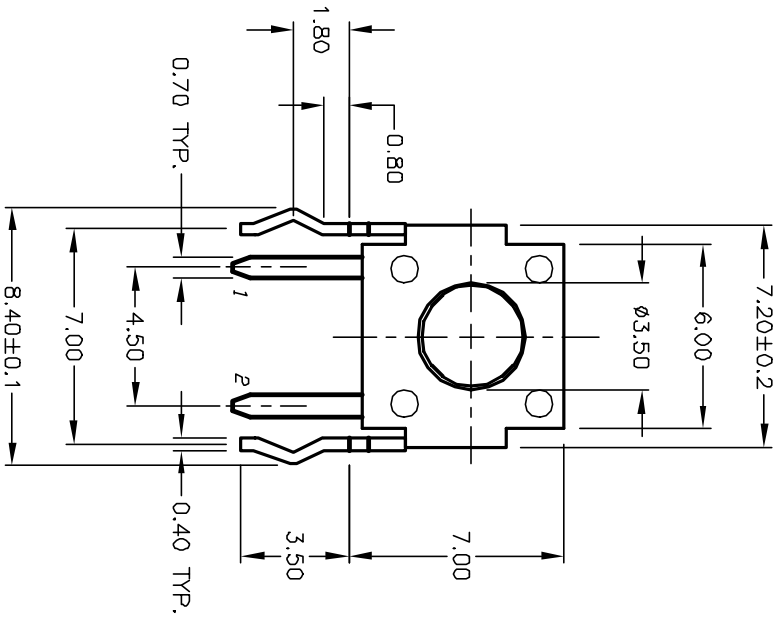

REV.	ECN No.	DESCRIPTION	DATE	CHKD
A	12370	RELEASED	12/10/02	CJB
THE INFORMATION CONTAINED IN THIS DOCUMENT IS PROPRIETARY TO E-SWITCH AND IS NOT TO BE COPIED OR TRANSFERRED				

TITLE	SCALE	DATE	DR	DWG	REV
TL 1105R F100 Q	4:1	--	--	P021224	A

