

RADIUS FEATURE TO I.D. TERMINAL 2 & 4 LOCATION

EPOXY SEAL AROUND TERM# 2 & 4

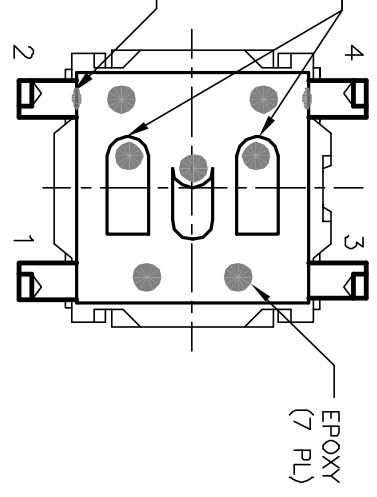

BOTTOM VIEW

RECOMMENDED P.C.B. LAYOUT

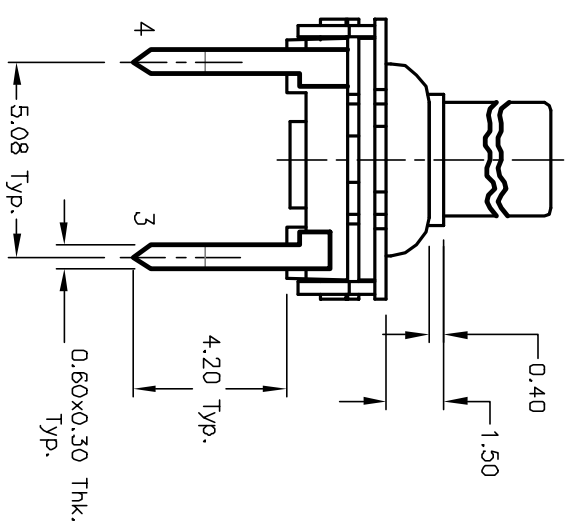
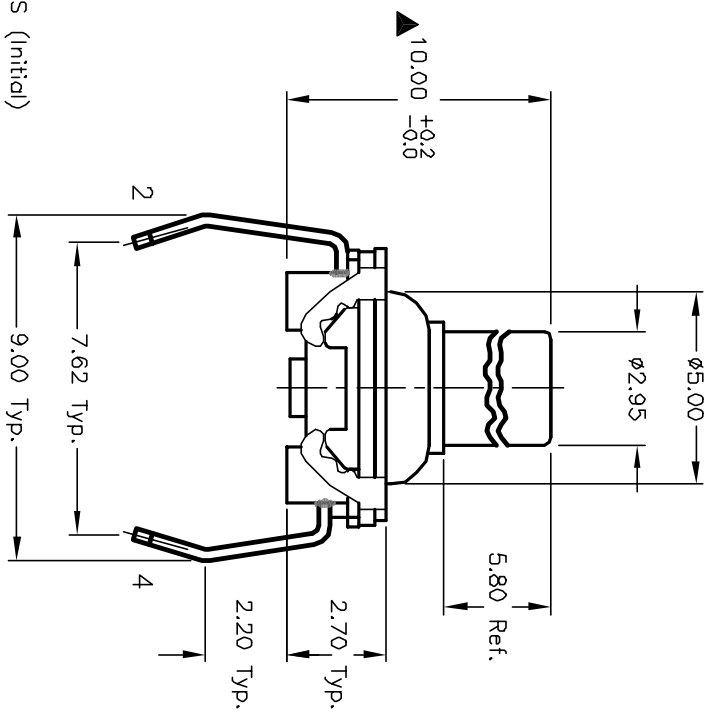
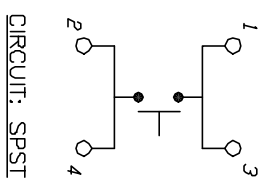

NOTES:

1. ALL DIMENSIONS IN MM
2. GENERAL TOLERANCE: X.X=±0.4
X:XX=±0.25
3. TERM. NOS. FOR REF. ONLY
4. ACTUATION FORCE: 300±75gf
5. TRAVEL TO MAKE: 0.3mm +0.4/0.0
6. RATING: 30mA, @12V DC
7. CONTACT RESISTANCE: 50 MILLI-OHMS (initial)
8. DIELECTRIC STRENGTH: 300 V RMS min at sea level.
9. ELECTRICAL LIFE CYCLE: 150,000 make & break cycles at full load.
10. ▲ DESIGNATE MAJOR DIMENSIONS.
11. OPERATING TEMP: -40°C to +85°C

B	12191	REVISED NOTE 9, ADD NOTE11	5/28/02	CB
A	10812	RELEASED FOR PRODUCTION	8/4/00	MM
REV.	ECN No.	DESCRIPTION	DATE	CHKD

TITLE		SCALE	DATE	DR	DWG	REV
GS 10.00 F300 QP WASHABLE TACT SWITCH		5:1	8/4/00	MM	L600002	B



THE INFORMATION CONTAINED IN THIS DOCUMENT IS PROPRIETARY TO E-SWITCH AND IS NOT TO BE COPIED OR TRANSFERRED