

RECOMMENDED P.C.B. LAYOUT

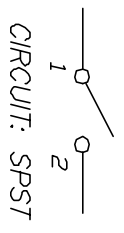

CIRCUIT: SPST

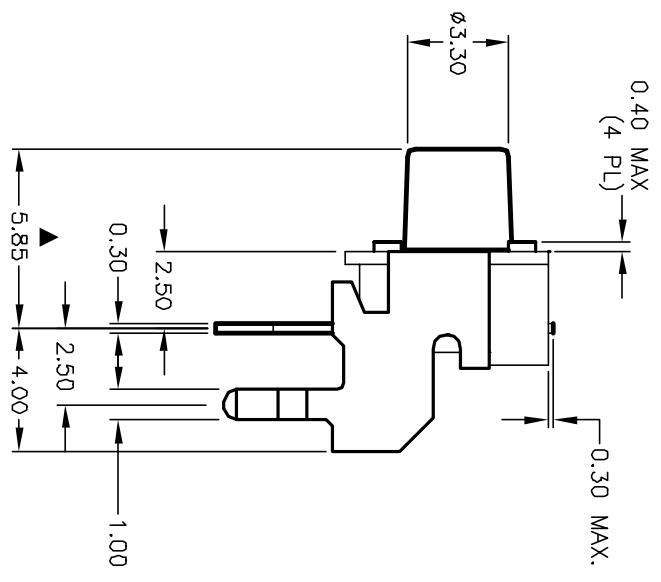
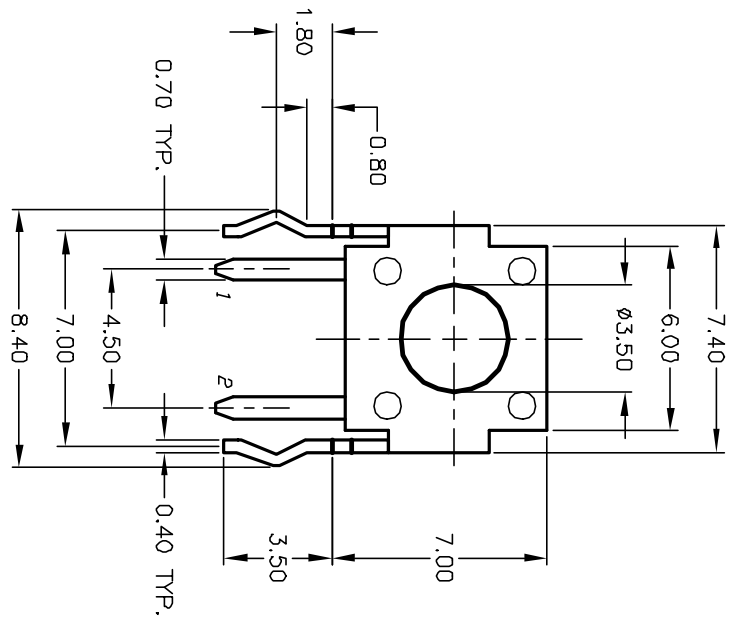

NOTES:

1. ALL DIMENSIONS IN MM
2. GENERAL TOLERANCE: X.X=±0.4
X.XX=±0.25
3. TERM. NDS. FOR REF. ONLY
4. RATING: 50mA, @12V DC
5. TRAVEL: 0.25±0.1mm
6. OPERATING FORCE: 160±50gf
7. CONTACT RESISTANCE: 100 milliohms Max.
8. ELECTRICAL LIFE: 100,000 CYCLES MIN.
9. DESIGNATE MAJOR DIMENSIONS
10. MATERIAL: PPS (STEM & BODY)

REV.	ECN No.	DESCRIPTION	DATE	CHKD
B	11842	REVISED AND REDRAWN	11/27/01	CJB

TITLE	SCALE	DATE	DR	DWG	REV
TL 1105 X F160 Q (STD BRACKET)	4:1	11/27/01	CJB	P020221	B

E-SWITCH®

THE INFORMATION CONTAINED IN THIS DOCUMENT IS PROPRIETARY TO E-SWITCH AND IS NOT TO BE COPIED OR TRANSFERRED