

RECOMMENDED P.C.B. LAYOUT

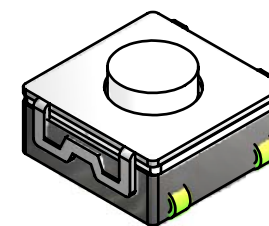

ISOMETRIC

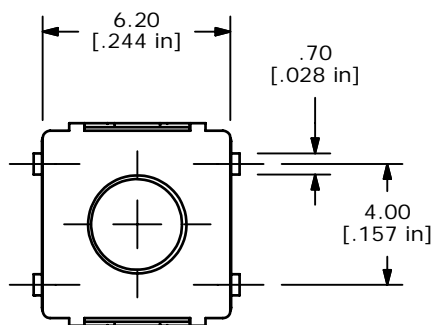
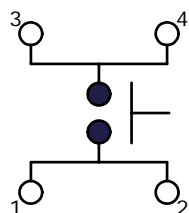

CIRCUIT: SPST

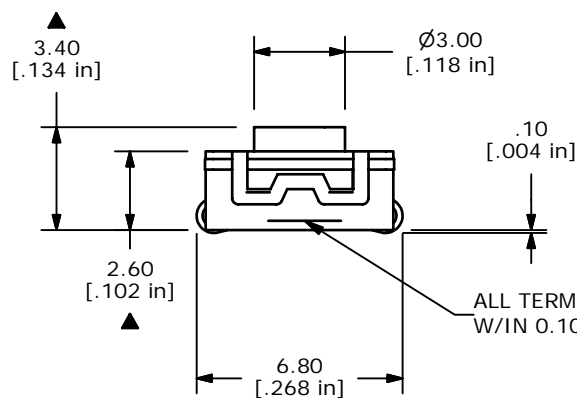

ALL TERMINALS MUST BE CO-PLANAR W/IN 0.10 [.004] TOTAL

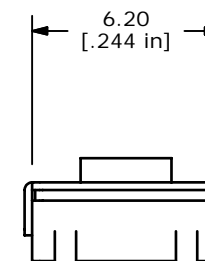

NOTES:

1. ALL DIMENSIONS IN MM [INCH]
2. GENERAL TOLERANCE: $x.x \pm 0.4$
 $x.xx \pm 0.25$
3. TERM. NOS. FOR REF. ONLY
4. RATING: 50mA, @12V DC
- ▲5. OPERATING FORCE: 260 ± 50 gf
6. TRAVEL: $0.25 +0.2/-0.1$ MM
7. CONTACT RESISTANCE: 100 OHMS MAX.
8. PACKAGING: TAPE AND REEL, 1600 PCS PER REEL
- ▲9. CONTACT MATERIAL: SILVER
10. ▲ DENOTES CRITICAL PARAMETER
11. 2002/95/EC (ROHS) COMPLIANT
12. MECHANICAL/ELECTRICAL LIFE: 100,000 CYCLES

E-SWITCH®

TITLE TL3304AF260QJ

D	16712	REVISED AND REDRAWN INVENTOR	11/29/06	TN
REV	PCR NO	DESCRIPTION	DATE	BY

THE INFORMATION CONTAINED IN THIS DOCUMENT IS PROPRIETARY TO E-SWITCH AND IS NOT TO BE COPIED OR TRANSFERRED

SCALE	DATE	DR	DWG	REV
4:1	11/29/2006	TN	P010544	D