

RECOMMENDED P.C.B. LAYOUT

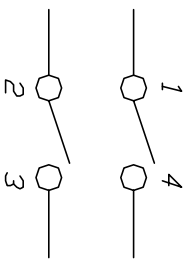
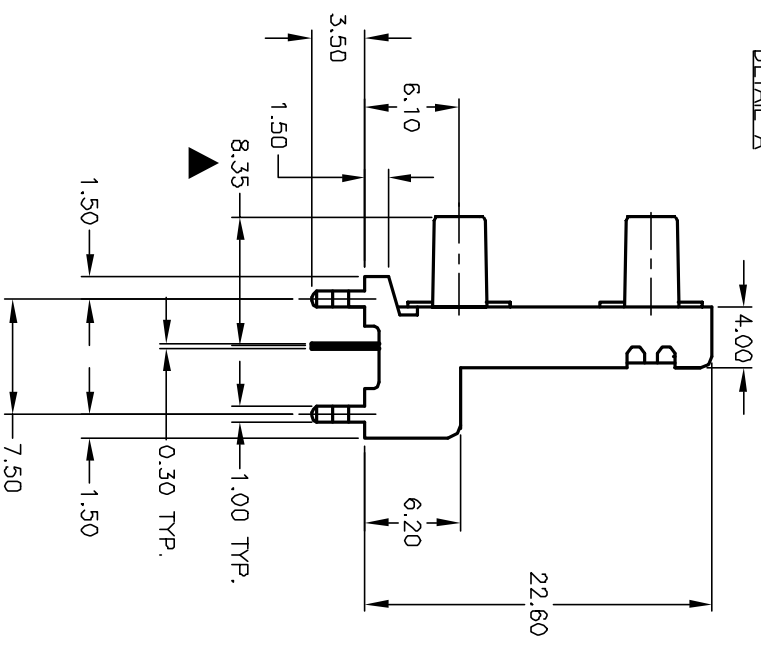
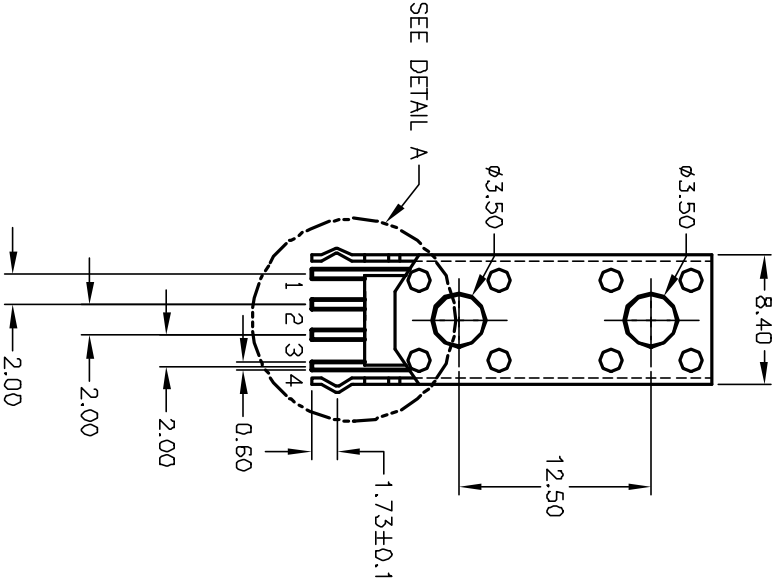
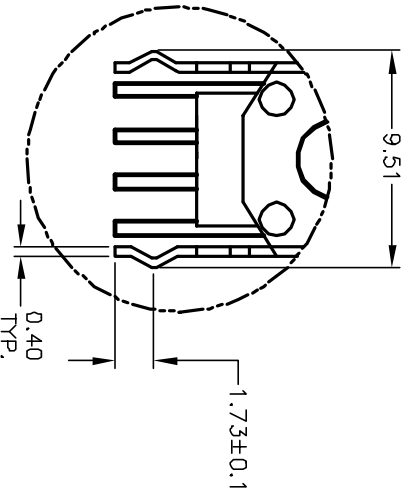
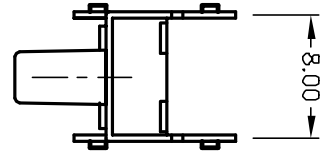

CIRCUIT: SPST

NOTES:

1. ALL DIMENSIONS IN MM
2. GENERAL TOLERANCE: X.X=±0.4
X.XX=±0.25
3. TERM. NOS. FOR REFERENCE ONLY.
4. RATING: 50mA @12VDC
5. TRAVEL: 0.25 +0.2/-0.1mm
6. CONTACT RESISTANCE: 100mΩ-1Ω OHMS MAX.
7. OPERATING FORCE: 160±50gf
8. CONTACT MATERIAL: SILVER

REV.	ECN No.	DESCRIPTION	DATE	CHKD
A	11848	RELEASED FOR PRODUCTION	12/6/01	CJB

TITLE	SCALE	DATE	DR	DWG	REV
TL53G F160 Q	2:1	12/6/01	CB	P010602	A

E-SWITCH®

THE INFORMATION CONTAINED IN THIS DOCUMENT IS PROPRIETARY TO E-SWITCH AND IS NOT TO BE COPIED OR TRANSFERRED