

THIS DRAWING IS UNPUBLISHED. RELEASED FOR PUBLICATION
 © COPYRIGHT BY TYCO ELECTRONICS CORPORATION. ALL RIGHTS RESERVED.

LOC	DIST	REVISIONS			
P	LTR	DESCRIPTION	DATE	DWN	APVD
AD	00	M	ECO-07-014425	18JUL07	MB MS

SPECIFICATIONS:

MATERIALS:
 CASE: PBT UL94HB, BLACK.
 COVER: STEEL ,TIN PLATE.
 ACTUATOR BUTTON: SEE P/N TABLE.
 MOVING CONTACT: PHOS BRONZE, SILVER.
 FIXED CONTACT/TERMINAL: BRASS, SILVER OVER NICKEL.

ELECTRICAL:
 MAX CONTACT RATING: 50MILLIAMPS@24V DC
 MIN CONTACT RATING: 10MICROAMPS@1V DC
 CONTACT RESISTANCE: 100 MILLIOHMS MAX.
 INSULATION RESISTANCE: 100 MEGOHMS MIN. @ 100 VDC.
 DIELECTRIC STRENGTH: 500 VAC 50/60 Hz FOR 1 MINUTE
 LIFE EXPECTANCY: 100,000 CYCLES.

MECHANICAL:
 ACTUATION FORCE: 160±50gf
 ACTUATION TRAVEL: .010 IN, (0.25 mm) APPROX.

ENVIRONMENTAL:
 OPERATING TEMPERATURE: -35°C TO +85°C
 STORAGE TEMPERATURE: -35°C TO +85°C

SOLDERABILITY:
 SOLDERABILITY EIA-364-52,CLASS 1,CATEGORY 2
 SOLDER HEAT RESISTANCE PER 109-202 CONDITION B

- NOTES:**
- ALL MATERIALS AND FINISHES SHALL COMPLY WITH EU DIRECTIVE 2002/95/EC OF 27JAN2003 (ROHS)
 - RADIAL TAPE PACKAGING PER AUGAT SPEC.#295.
 - SPECIFICATIONS SUBJECT TO CHANGE WITHOUT NOTIFICATION.

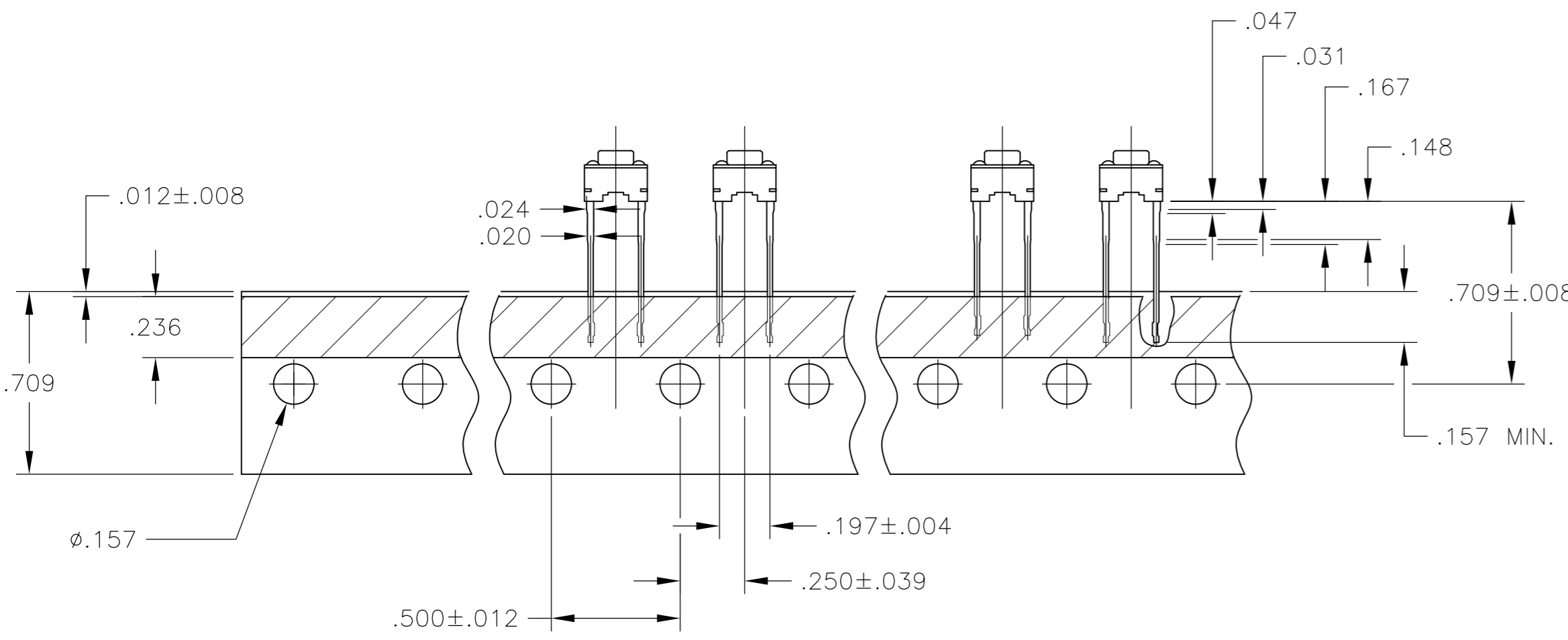
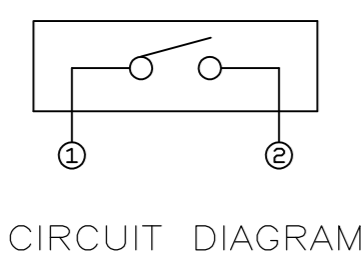
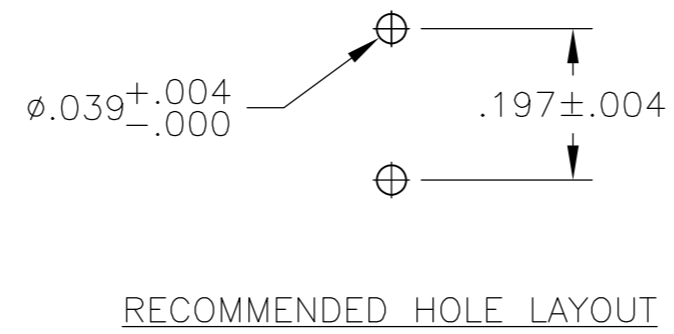
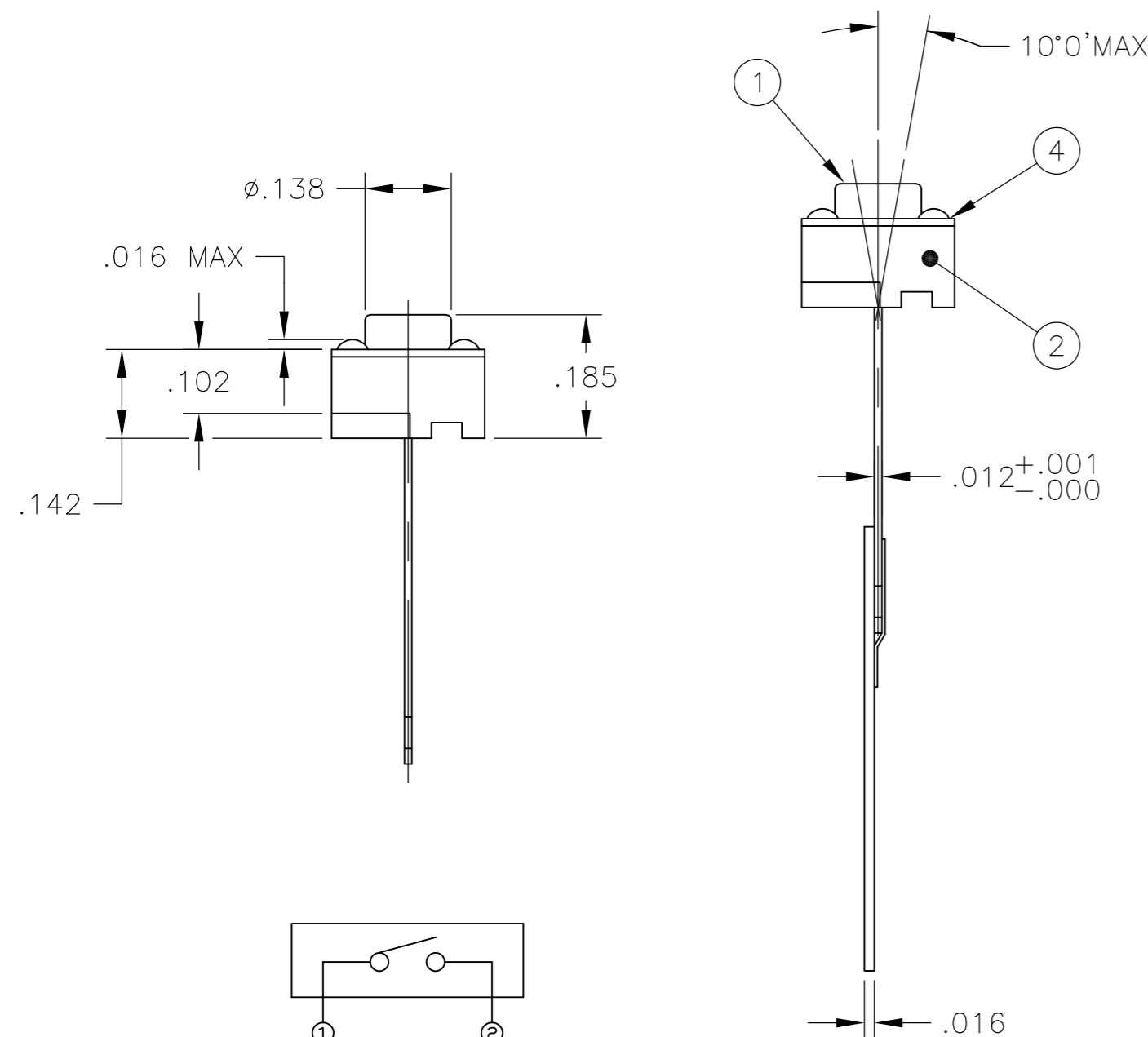
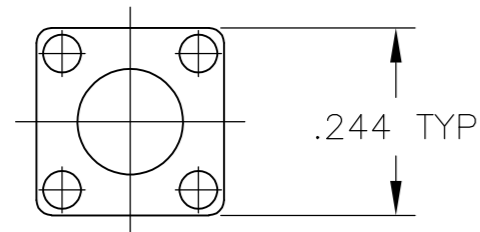

260 +/-50 grams	Nylon 66	RED	.512 (13.0)	FSM14JRT	1571010-1
260 +/-50 grams	PBT	RED	.374 (9.5)	FSM8JART	147871-1
160 +/-50 grams	PBT	BLACK	.374 (9.5)	FSM8JRT	147694-1
260 +/-50 grams	Nylon 66	RED	.276 (7.0)	FSM6JART	1571402-1
160 +/-50 grams	Nylon 66	BLUE	.276 (7.0)	FSM6JRT	4-1437565-8
260 +/-50 grams	PBT	RED	.197 (5.0)	FSM4JART	147997-1
160 +/-50 grams	Nylon 66	BLACK	.197 (5.0)	FSM4JRT	4-1437565-0
160 +/-50 grams	PBT	BLACK	0.169 (4.3)	FSM2JRT	2-1437565-6
260 +/-50 grams	PBT	RED	0.169 (4.3)	FSM2JART	2-1437565-2
ACTUATION FORCE	ACTUATOR MATERIAL	ACTUATOR COLOR	DIM H	T&B P/N	PART NUMBER

THIS DRAWING IS A CONTROLLED DOCUMENT.

DWN	M.BINNER	29SEP05
CHK	M.SARVER	29SEP05
APVD	M.SARVER	29SEP05

Tyco Electronics Corporation
Harrisburg, PA 17105-3608

NAME: SWITCH, PUSHBUTTON

SIZE	CAGE CODE	DRAWING NO	RESTRICTED TO
A2	00779	2-1437565-2	-

MATERIAL: SEE SPECIFICATIONS
 FINISH: SEE SPECIFICATIONS
 WEIGHT: -
 SCALE: 4:1
 SHEET: 1 of 1
 REV: M

2-1437565-2

A