

NOTES:

1. ALL DIMENSIONS IN MM [INCH]
2. GENERAL TOLERANCE: x.xx ± 0.4
x.xx ± 0.25
3. TERM. NOS. FOR REF. ONLY
4. RATING: 50mA, @12V DC
5. TRAVEL: 0.25±0.1mm
6. CONTACT RESISTANCE: 50m ohms max initial.MOS & TTC COMPATIBLE
7. ELECTRICAL LIFE: 5 MILLION CYCLES.
8. INSULTION RESISTANCE: 100M ohms min.
9. OPERATING TEMP.: -30°C to 85°C
10. ▲ DENOTES CRITICAL PARAMETER
- ▲11. CONTACTS: SILVER
- ▲12. OPENING FORCE: 65 GRAMS
13. PACKAGE: BULK, 750 PIECES PER POLYBAG
14. 2002/95/EC (ROHS) COMPLIANT

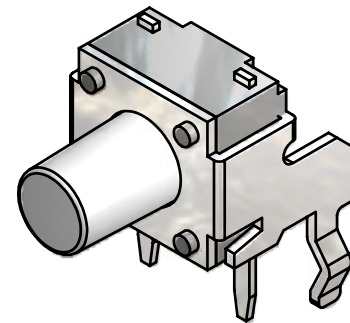

ISOMETRIC

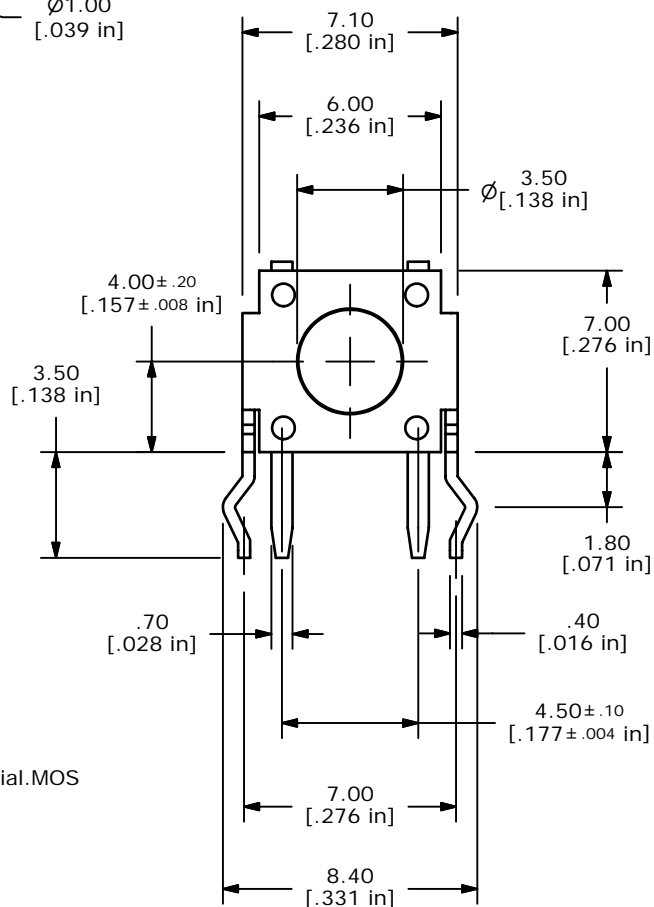
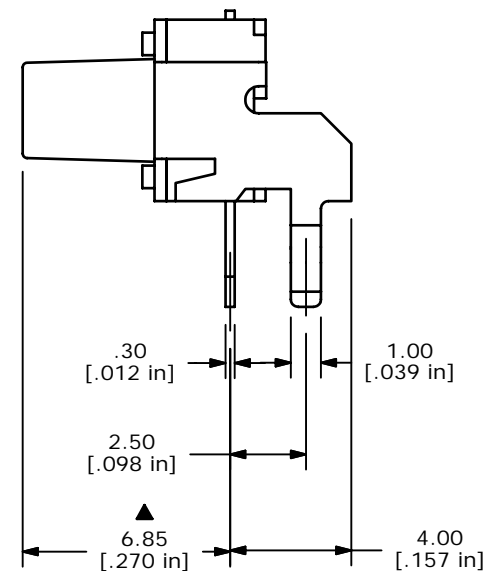

E-SWITCH®

A	16609	RELEASED FOR PRODUCTION	11/8/2006	TN
REV	PCR NO	DESCRIPTION	DATE	BY

TITLE LL1105MF065Q				
SCALE	DATE	DR	DWG	REV
4:1	11/8/2006	TN	P010244	A

THE INFORMATION CONTAINED IN THIS DOCUMENT IS PROPRIETARY TO E-SWITCH AND IS NOT TO BE COPIED OR TRANSFERRED