

ISOMETRIC

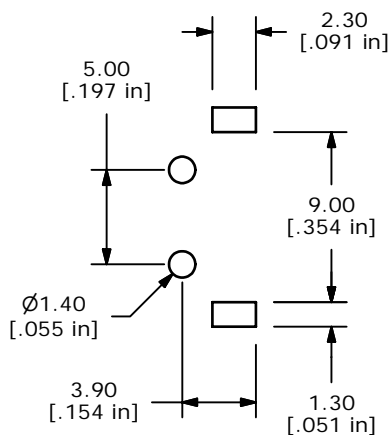

P.C. MOUNTING

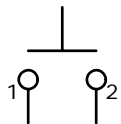

CIRCUIT: SPST

NOTES:

1. ALL DIMENSIONS IN MM [INCH]
2. GENERAL TOLERANCE: X.X=±0.4
X.XX=±0.25
3. TERM. NOS. FOR REF. ONLY
4. RATING: 50mA @12VDC
- ▲ 5. CONTACT MATERIAL: SILVER
6. TRAVEL: 0.30±0.15mm
7. OPERATING FORCE: 160±50gf
8. CONTACT RESISTANCE: 100mΩ MAX.
- ▲ 9. ELECTRICAL LIFE: 100,000 CYCLES MIN
10. ▲ DENOTES CRITICAL DIMENSION

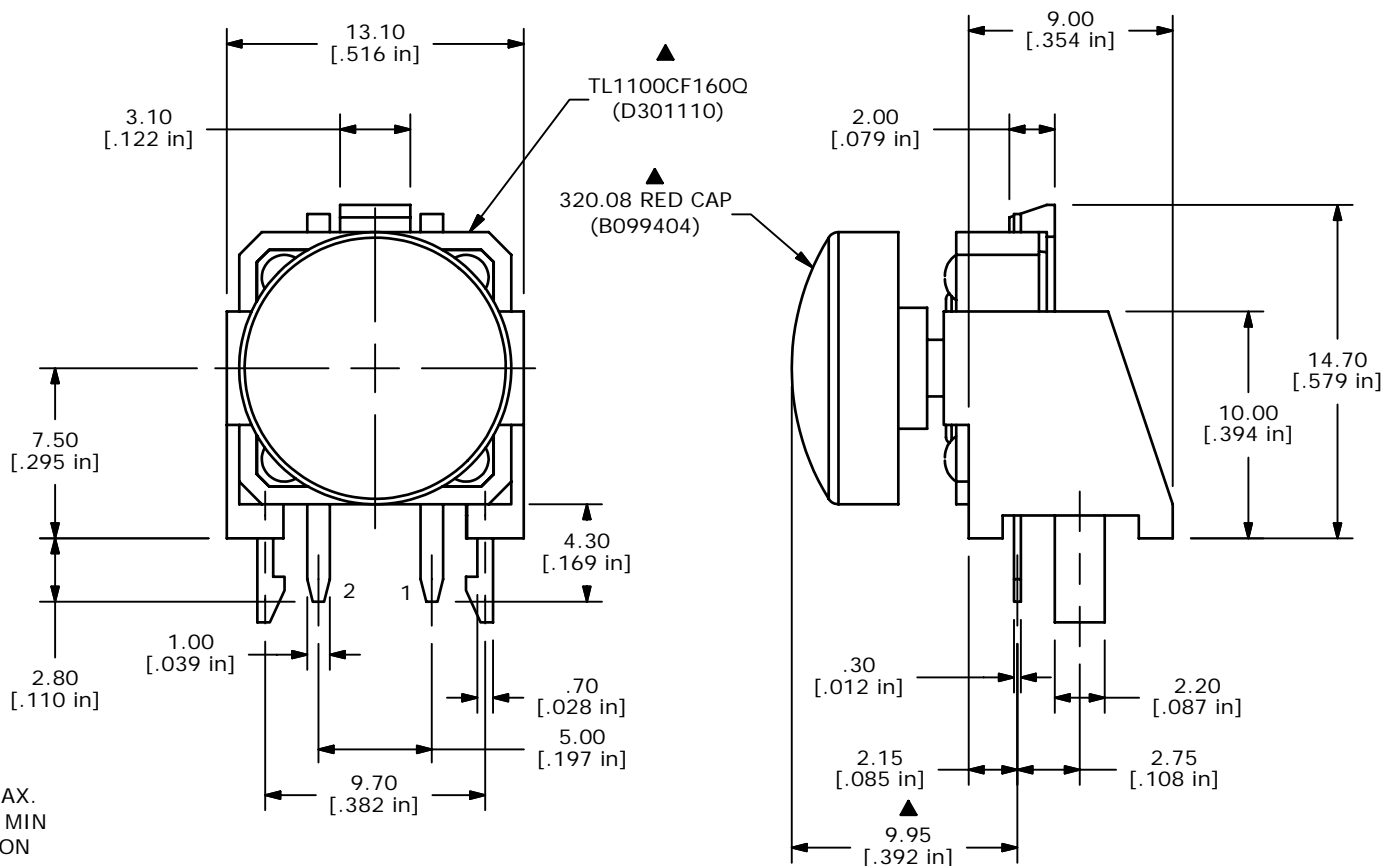

A	15025	RELEASED FOR PRODUCTION	7/6/05	JB
REV	PCR NO	DESCRIPTION	DATE	BY

TITLE TL1100CF160Q.08RED				
SCALE	DATE	DR	DWG	REV
1:1	7/6/2005	JB	XD0402A	A

THE INFORMATION CONTAINED IN THIS DOCUMENT IS PROPRIETARY TO E-SWITCH AND IS NOT TO BE COPIED OR TRANSFERRED