

RECOMMEND P.C.B. LAYOUT

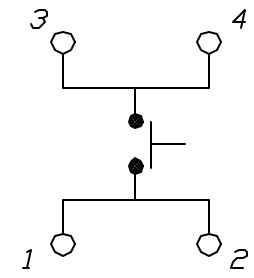
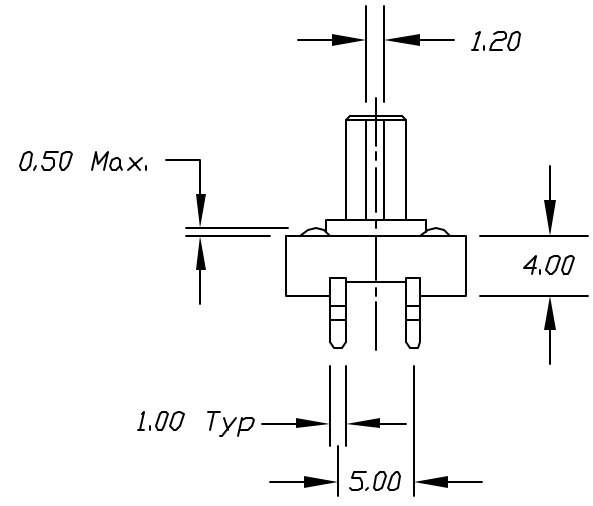
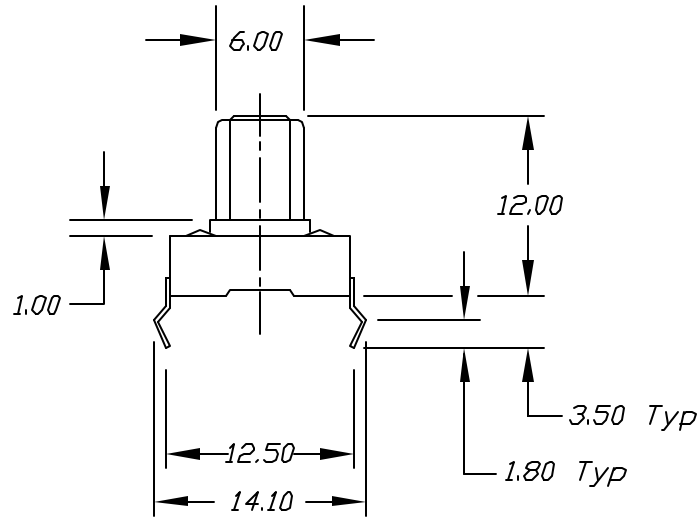

CIRCUIT: SPST
CONTACT CONFIGURATION

- NOTES:
1. ALL DIMENSIONS IN MM
 2. TERM. NOS. FOR REF ONLY
 3. RATING: DC 12V, 50mA
 4. TRAVEL: 0.3±0.15mm
 5. CONTACT RESISTANCE: 100m Ohms Max.

				E-SWITCH®					
				TITLE TL 1100 F F260 Q					
A	RELEASED FOR PRODUCTION			SCALE 2:1		DATE 11/10/97	DR MM	DWG P001105	REV A
REV.	DESCRIPTION	DATE	CHKD						
<small>THE INFORMATION CONTAINED IN THIS DOCUMENT IS PROPRIETARY TO E-SWITCH AND IS NOT TO BE COPIED OR TRANSFERRED</small>				TOLERANCES	±0.4	±0.25			
				0.0	0.00				