

RECOMMENDED P.C.B. LAYOUT
SCALE 3:1

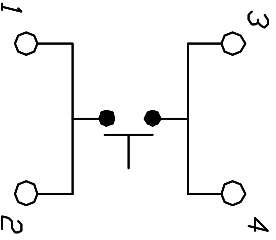
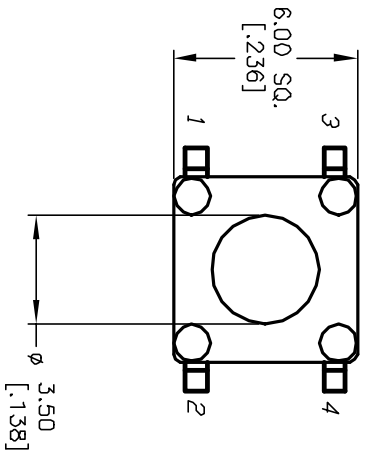

CIRCUIT: SPST

NOTES:

1. ALL DIMENSIONS IN MM [INCH]
2. GENERAL TOLERANCE: X.X=±0.4
X.XX=±0.25
3. TERM. NOS. FOR REFERENCE ONLY.
4. RATINGS: 12VDC, 50mA
5. OPERATING FORCE: 100±50gf
6. TRAVEL: 0.25±0.1mm
7. CONTACT RESISTANCE: 100 MILLI Ω Max.
8. DIELECTRIC STRENGTH: 250V RMS min.
9. INSULATION RESISTANCE: 100 Mega Ω min.
10. ELECTRICAL LIFE: 100,000 CYCLES min.
11. DESIGNATE MAJOR FEATURE:

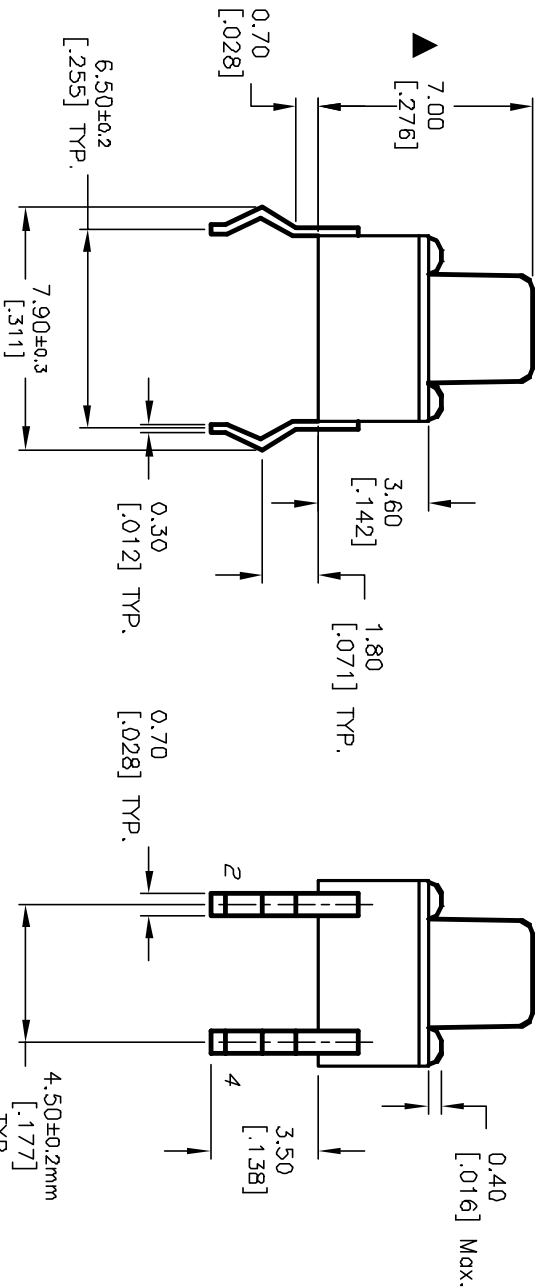

E-SWITCH®

A		11621	RELEASED FOR PRODUCTION	8/20/01	CJB	TITLE	
REV.	ECN No.		DESCRIPTION	DATE	CHKD	TL1105F F100 Q	
THE INFORMATION CONTAINED IN THIS DOCUMENT IS PROPRIETARY TO E-SWITCH AND IS NOT TO BE COPIED OR TRANSMITTED							
SCALE		4:1		DATE	---	DR	---
REV		A		DWG	P010027		