

RECOMMENDED P.C.B. LAYOUT

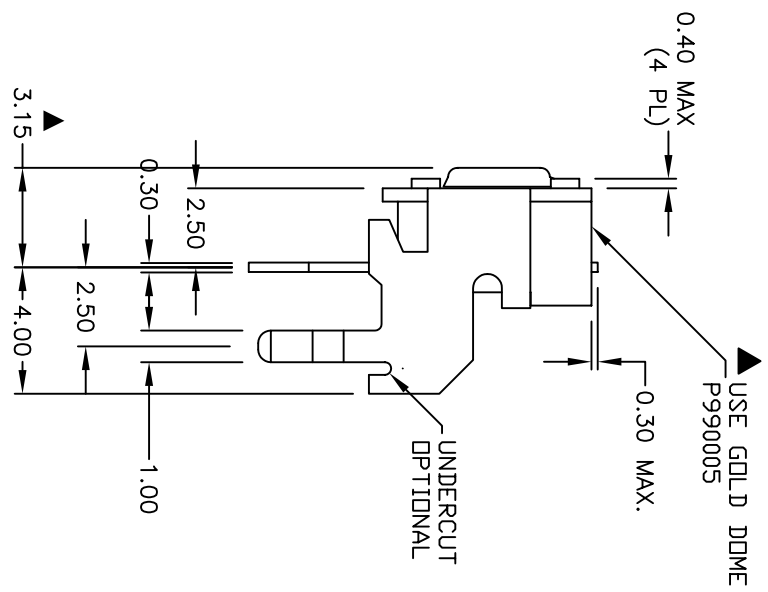
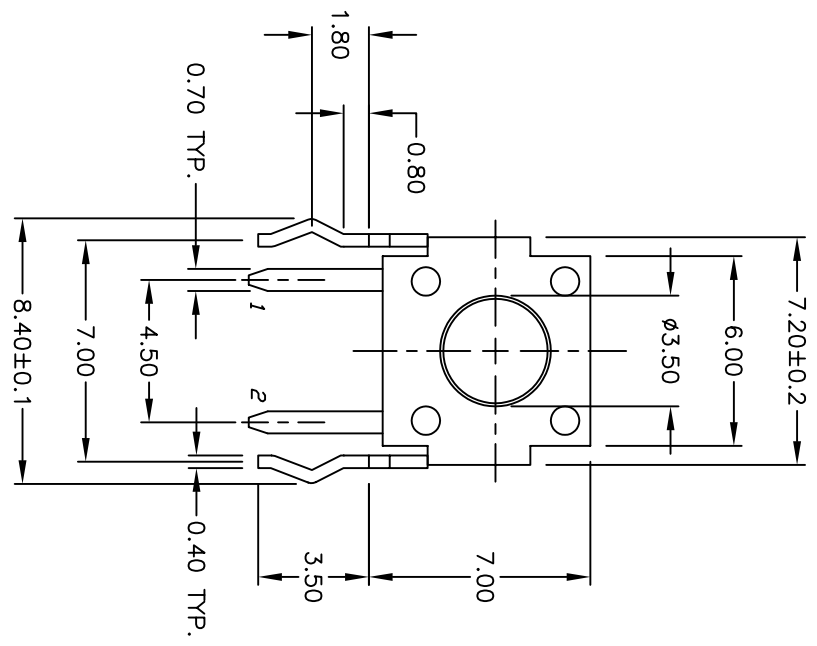
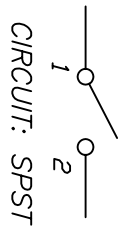

NOTES:

1. ALL DIMENSIONS IN MM
2. GENERAL TOLERANCE: X.X=±0.4  
X.XX=±0.25
3. TERM. NOS. FOR REF. ONLY
4. RATING: 50mA, @12V DC
5. TRAVEL: 0.25±0.1mm
6. OPERATING FORCE: 160±50gf
7. CONTACT RESISTANCE: 100 milliohms Max.
8. ELECTRICAL LIFE: 100,000 CYCLES MIN.
9. ▲ DESIGNATE MAJOR FEATURE
10. ACTUATOR COLOR: BROWN
11. HOUSING COLOR: BLACK

B	16112	ADD GOLD DOME NOTE	6/6/06	CT
A	12918	RELEASED	3/17/03	AR
REV.	ECN NO.	DESCRIPTION	DATE	CHKD

TITLE		SCALE		DATE		DR		DWG		REV	
TL 1105W F160 R		4:1		3/17/03		AR		P020225		B	



THE INFORMATION CONTAINED IN THIS DOCUMENT IS PROPRIETARY TO E-SWITCH AND IS NOT TO BE COPIED OR TRANSFERRED