

ISOMETRIC

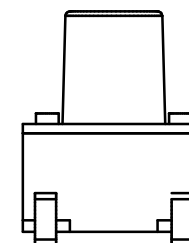

- NOTES:
1. ALL DIMENSIONS IN MM
  2. GENERAL TOLERANCE: X.X = ±0.4  
X.XX = ±0.25
  3. TERM. NOS. FOR REFERENCE ONLY.
  4. RATING: 12VDC, 50mA
  5. OPERATING FORCE: 100 ± 50 gms
  - ▲ 6. TRAVEL: 0.3mm ± 0.15
  7. CONTACT RESISTANCE: 100 MILLI OHMS MAX. (INITIAL)
  8. MECHANICAL/ELECTRICAL LIFE 100,000 CYCLES MIN.
  - ▲ 9. SILVER CONTACTS
  10. PACKAGE: TAPE AND REEL, 700 PER REEL
  11. ▲ DENOTES CRITICAL PARAMETER

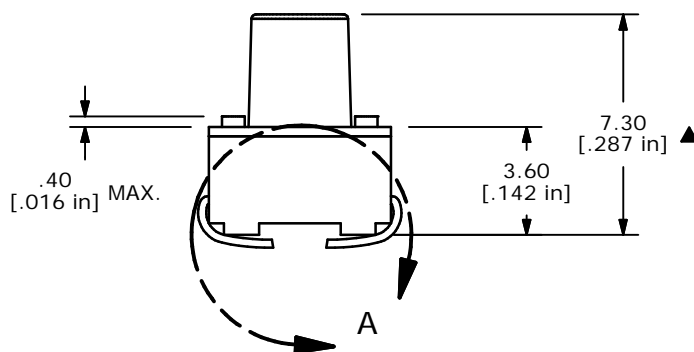
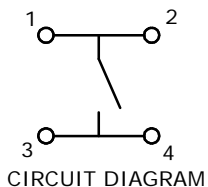
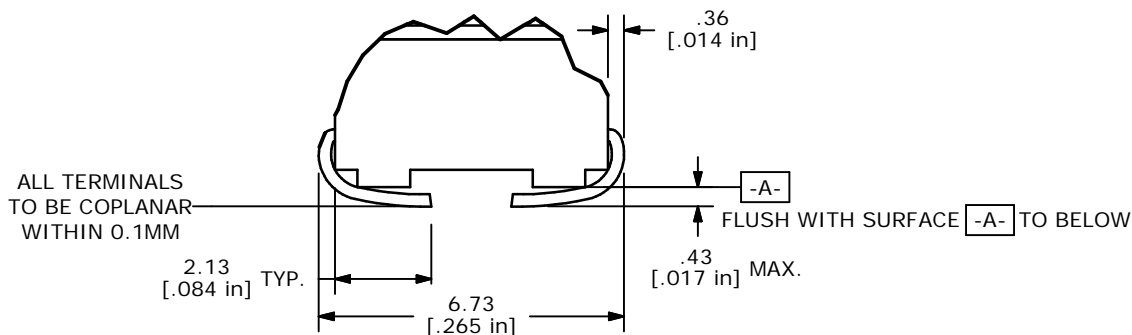

DETAIL A  
SCALE 6 : 1

**E-SWITCH®**

B	14545	CORRECT RATING NOTE	11/28/04	AR
A	13958	RELEASED FOR PRODUCTION	4/26/04	AR
REV	PCR NO	DESCRIPTION	DATE	BY

TITLE TL3301EF100QJ				
SCALE	DATE	DR	DWG	REV
4:1	4/26/04	AR	D310633	B

THE INFORMATION CONTAINED IN THIS DOCUMENT IS PROPRIETARY TO E-SWITCH AND IS NOT TO BE COPIED OR TRANSFERRED