

PC MOUNTING

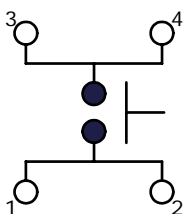

CIRCUIT: SPST

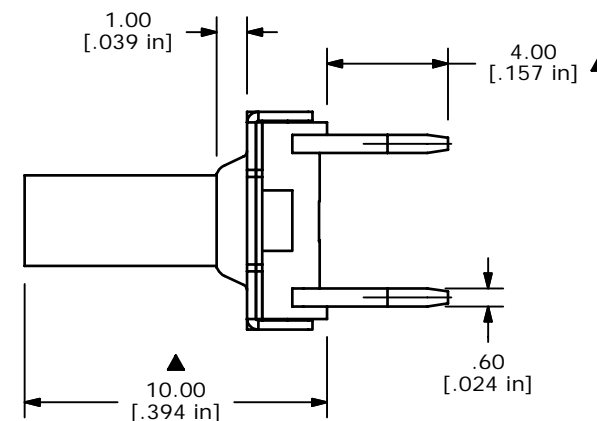
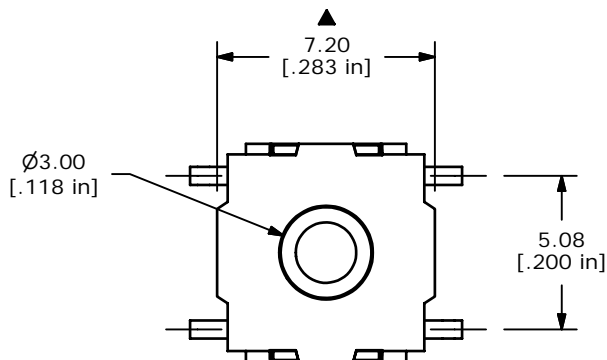
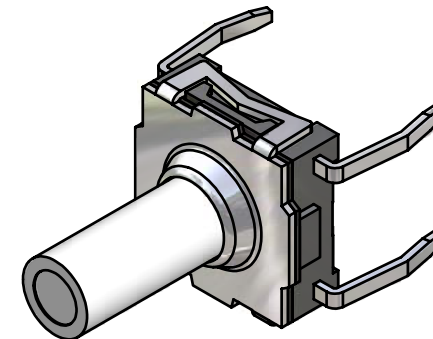
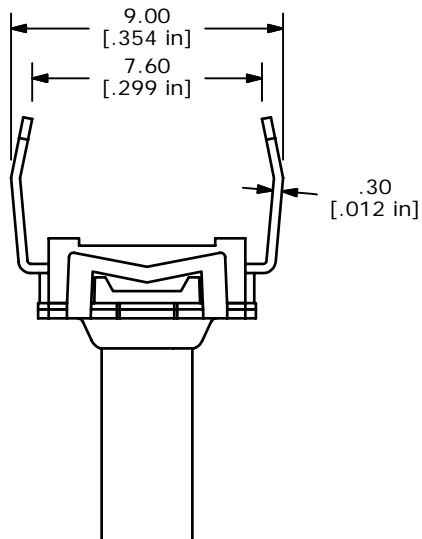

NOTES

1. ALL DIMENSIONS IN MM [INCH]
2. GENERAL TOLERANCE: X.X=±0.4  
X.XX=±0.25
3. TERMINAL NUMBERS FOR REF. ONLY.
- ▲ 4. OPERAING FORCE: 300±50gf
5. OPERATING LIFE: 150,000 CYCLES
6. TRAVEL: 0.5±0.1mm
7. SWITCH VOLAGE MAX: 50V
8. SWITCH POWER MAX: 1VA
9. CONTACT RESISTANCE: 50m Ω 5VDC
10. INSULATION RESISTANCE: 10,000M Ω MIN.
11. BOUNCE MAX: <5m SEC
12. OPERATING TEMPERATURE: -40°C TO 85°C
13. STORAGE TEMPERATURE: -55°C TO 85°C
14. PACKAGING: TUBE 60 PCS. PER
15. ▲ DENOTES CRITICAL PARAMETER
16. 2002/95/EC (ROHS) COMPLIANT

**E-SWITCH®**

TITLE TL6100DF300QPSSDOME

B	15884	REVISE AND REDRAWIN	3/21/06	PH
REV	PCR NO	DESCRIPTION	DATE	BY

SCALE	DATE	DR	DWG	REV
4:1	3/21/2006	PH	D350020	B

THE INFORMATION CONTAINED IN THIS DOCUMENT IS PROPRIETARY TO E-SWITCH AND IS NOT TO BE COPIED OR TRANSFERRED