

SWITCH FUNCTION		
POS. 1	POS. 2	POS. 3
ON	NONE	ON
2-3, 5-6, 8-9	N/A	2-1, 5-4, 8-7

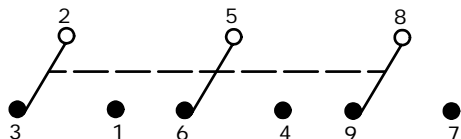

CIRCUIT: 3PDT

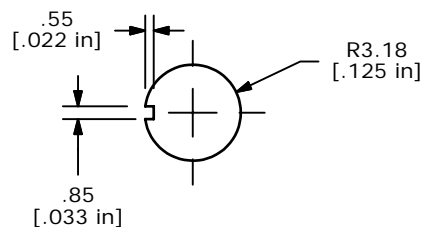

RECOMMENDED PANEL MOUNTING

NOTE:

1. ALL DIMENSIONS IN MM [INCH]
2. GENERAL TOLERANCE: X.X=±0.4
X.XX=±0.25
3. TERMINAL NUMBERS FOR REF ONLY
- ▲ 4. PLATING MATERIAL: SILVER
5. RATING: 2 AMPS @250VAC
5 AMPS @120VAC OR 28VDC
6. ELECTRIC LIFE: 40,000 make-and-break cycles at full load.
7. INSULATION RESISTANCE: 1,000 Mega-ohm min.
8. DIELECTRIC STRENGTH: 1,000 V RMS @sea level.
9. OPERATING TEMP.: -30°C to 85°C
10. ▲ DENOTES CRITICAL PARAMETER.
11. 2002/95/EC (ROHS) COMPLIANT

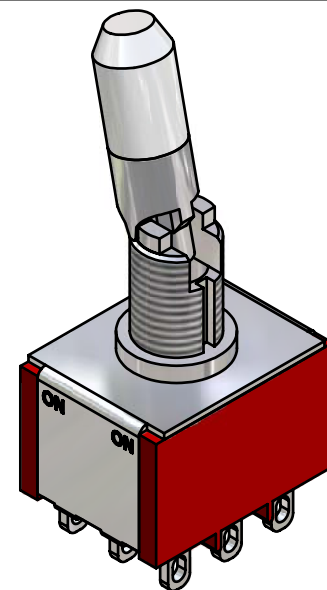
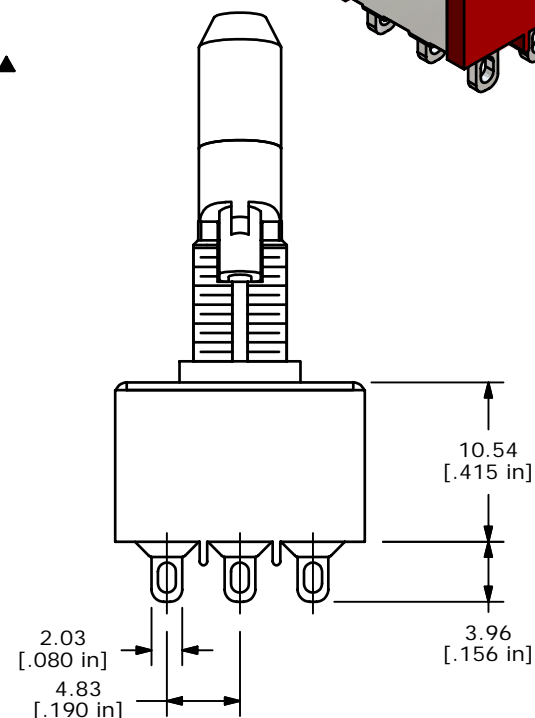
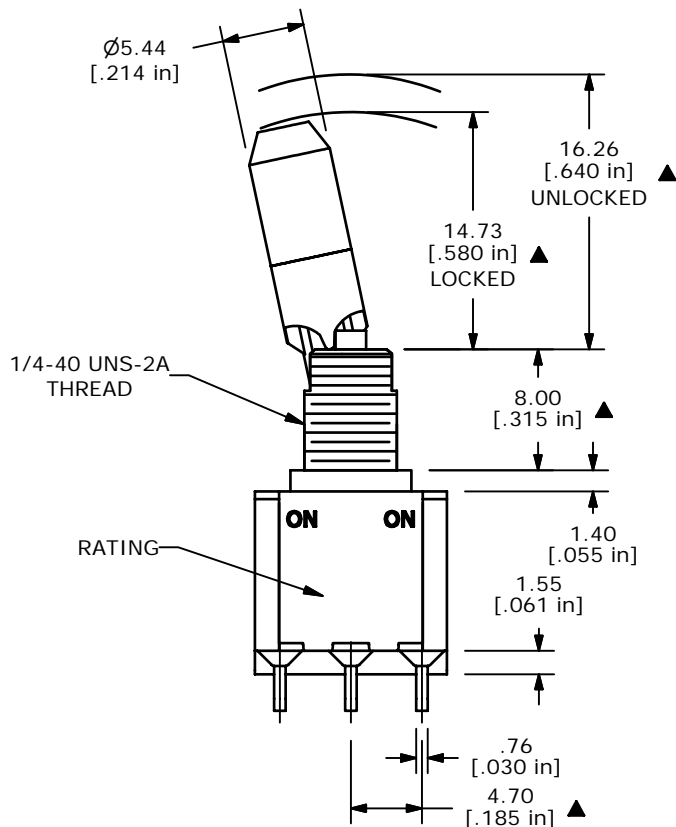
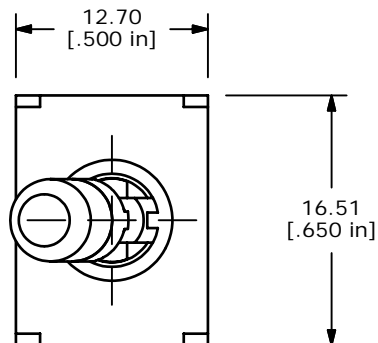

E-SWITCH®

TITLE 1003P1K2B25M1QE				
SCALE 2:1	DATE 5/24/2006	DR CT	DWG T131032	REV A

A	16032	NEW PART RELEASE	5/24/06	CT
REV	PCR NO	DESCRIPTION	DATE	BY

THE INFORMATION CONTAINED IN THIS DOCUMENT IS PROPRIETARY TO E-SWITCH AND IS NOT TO BE COPIED OR TRANSFERRED