

ISOMETRIC

SWITCH FUNCTION		
POS. 1	POS. 2	POS. 3
ON	ON	ON
2-3, 5-6	2-3, 5-4	2-1, 5-4

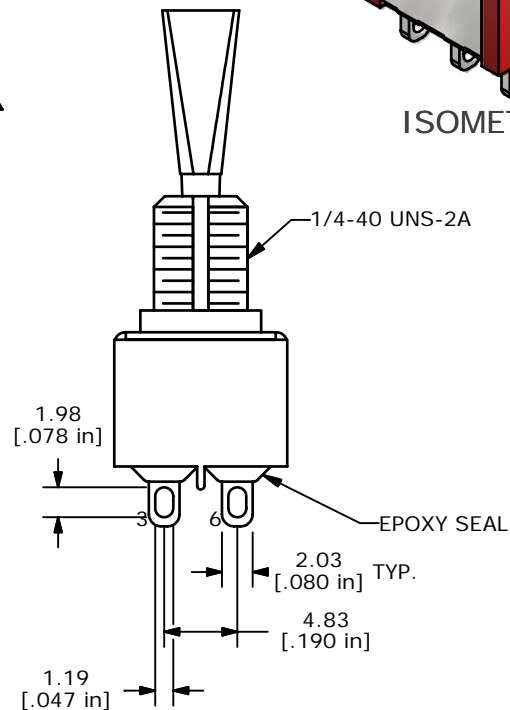
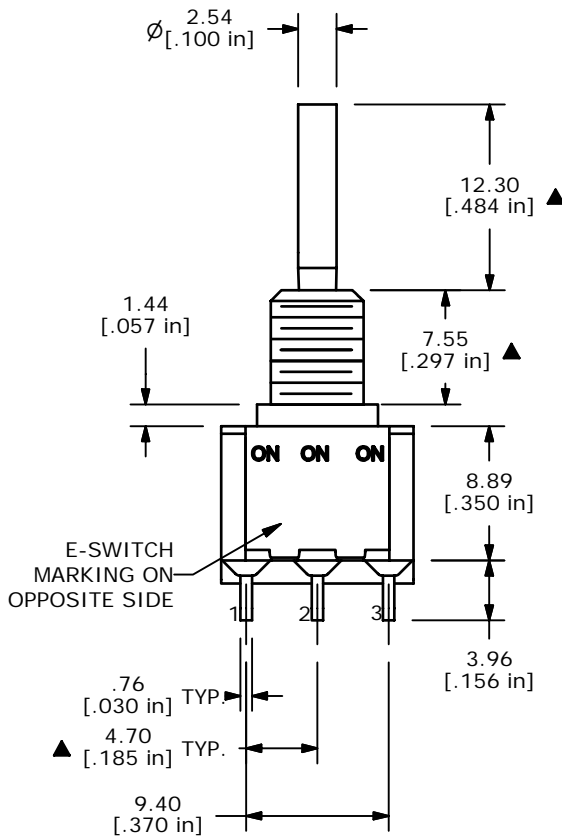

- NOTE:
1. ALL DIMENSIONS IN MM [INCH]
 2. GENERAL TOLERANCE: X.X=±0.4
X.XX=±0.25
 3. TERMINAL NUMBERS FOR REF ONLY
 - ▲ 4. PLATING MATERIAL: GOLD
 5. RATING: 0.4VA MAX @ 20V MAX (AC or DC)
 6. ELECTRIC LIFE: 40,000 make-and-break cycles at full load.
 7. INSULATION RESISTANCE: 1,000 Mega-ohm min.
 8. DIELECTRIC STRENGTH: 1,000 V RMS @ sea level.
 9. OPERATING TEMP.: -30°C to 85°C
 10. ▲ DENOTES CRITICAL PARAMETER.
 11. 2002/95/EC (ROHS) COMPLIANT

E-SWITCH®

B	16875	FIXED SWITCH FUNCTION	1/16/2007	TN
A	16025	RELEASED FOR PRODUCTION	5/18/06	CT
REV	PCR NO	DESCRIPTION	DATE	BY

TITLE 100DP6T6B11M1RE

THE INFORMATION CONTAINED IN THIS DOCUMENT IS PROPRIETARY TO E-SWITCH AND IS NOT TO BE COPIED OR TRANSFERRED

SCALE	DATE	DR	DWG	REV
2:1	1/16/2007	TN	T128067	B