

Crimp Height Gage 904170-1

Crimp Height Gage 904170-1

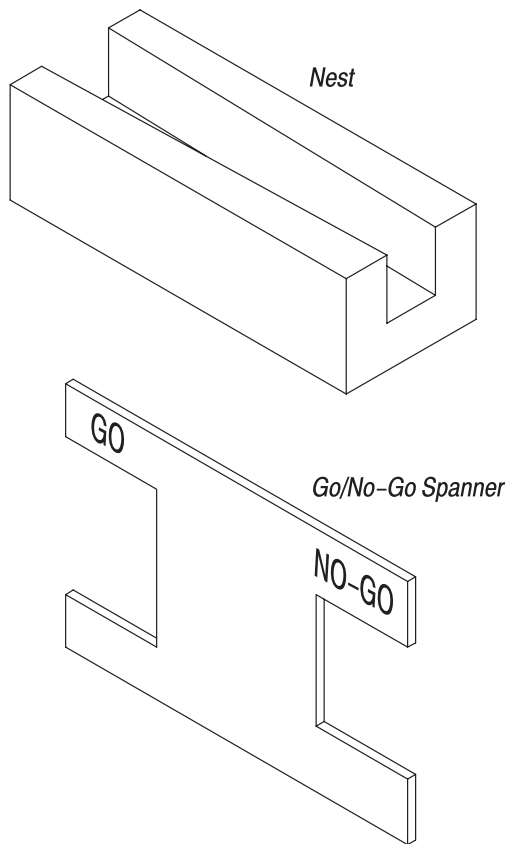

Figure 1

1. INTRODUCTION

This instruction sheet covers the setup and use of the Crimp Height Gage 904170-1 for 2, 4, 6, 8, and 10 position Modular Plugs. Note that 4-position handset and 6-position offset connectors are *not* included. Read these instructions thoroughly before using the gage.

The gage has been manufactured to be used as a quick verification of acceptable crimp height. Gages such as this must be kept clean and calibrated on a scheduled basis to maintain the integrity of the measurement process.



All dimensions on this document are in metric units [with U.S. customary units in brackets]. Figures and illustrations are for identification only and are not drawn to scale.

Reason for revision is given in Section 5, REVISION SUMMARY.

2. DESCRIPTION (Figure 1)

This gage consists of a connector nest and a GO/NO-GO spanner.

3. OPERATION PROCEDURES

1. Push down firmly on the crimped connector and slide the connector into the nest, wedging it in to hold it tightly.
2. While holding the crimped connector in the nest, slide the go end of the spanner over each contact as shown in Figure 2. Repeat this procedure with the other end of the spanner.



Do not force spanner over plug. Damage to the gold plated contacts and/or spanner may result.

The contact crimp height listed in Application Specifications 114-6016 and 114-6063 is 6.02 ± 0.13 mm [$.237 \pm .005$ in.]. If both ends of the spanner pass over a contact, that contact's crimp height is below the allowed tolerance. If both ends fail to pass over a contact, that contact is above the allowed tolerance.

4. MAINTENANCE

The two parts of the crimp height gage should be stored with a light film of oil to prevent corrosion.

5. REVISION SUMMARY

- Updated document to corporate requirements
- Added dimensions and nomenclature to Figures 1 and 2
- Added new Figure 3

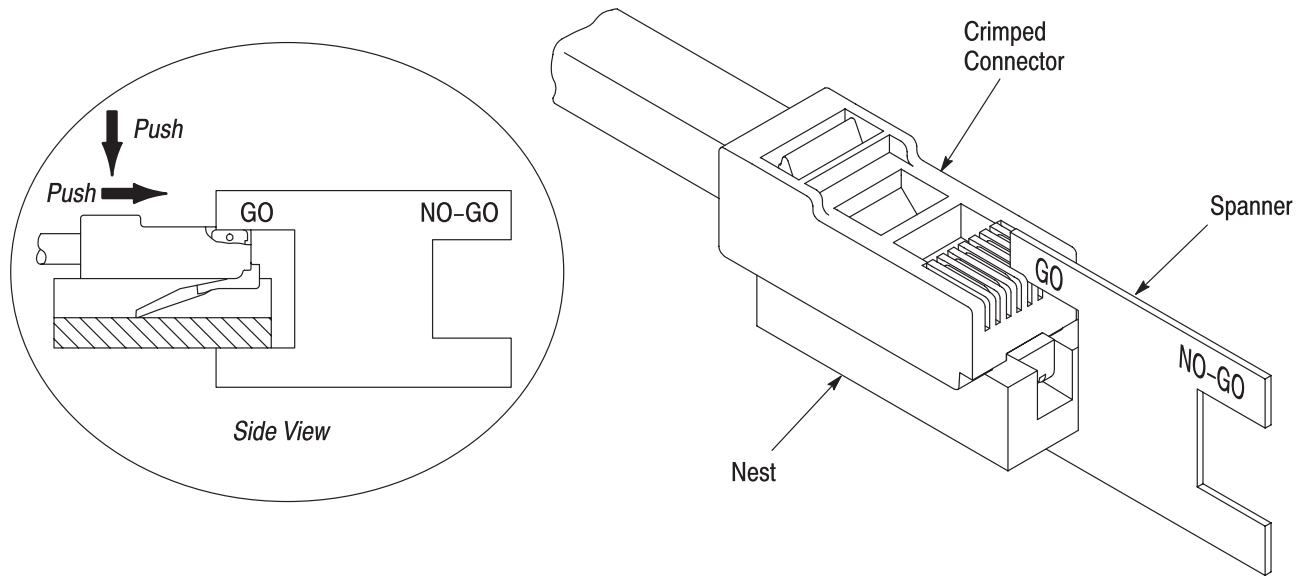
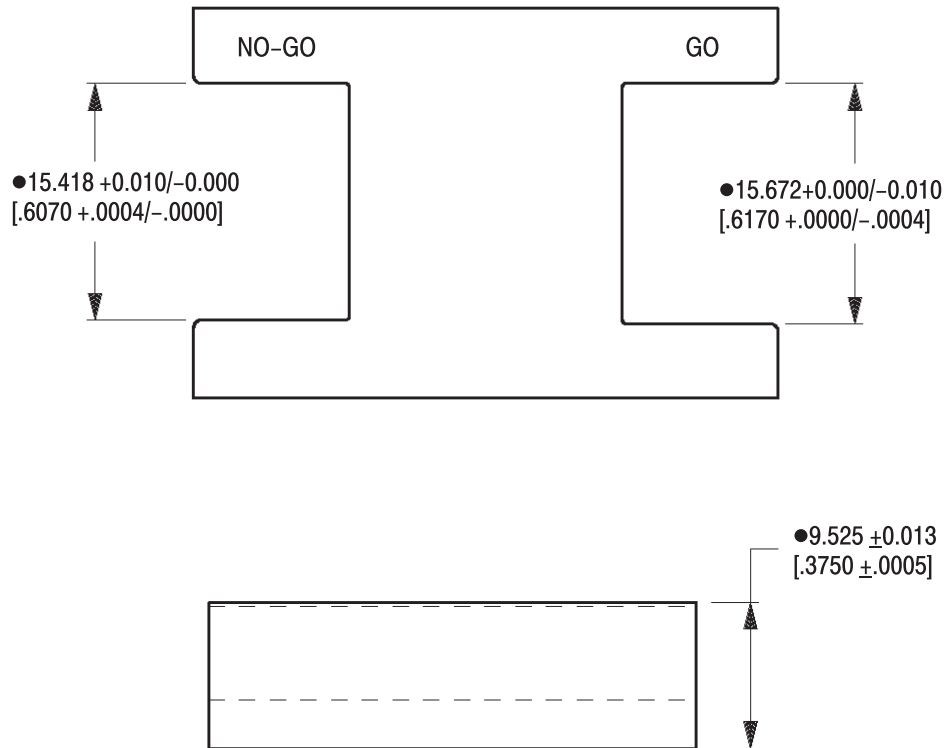

Figure 2



•These Dimensions are Reference for Checking Calibration

Figure 3