

HRS HR22 SERIES HIGH-PERFORMANCE COMPACT CIRCULAR CONNECTORS

Scope

The HR22 Series are 20-pin compact circular connectors developed as an interface between machine tool motors and operation panels, with a screw coupling

type locking mechanism to prevent unlocking due to motor vibration, and are available in either waterproof or non-waterproof types.

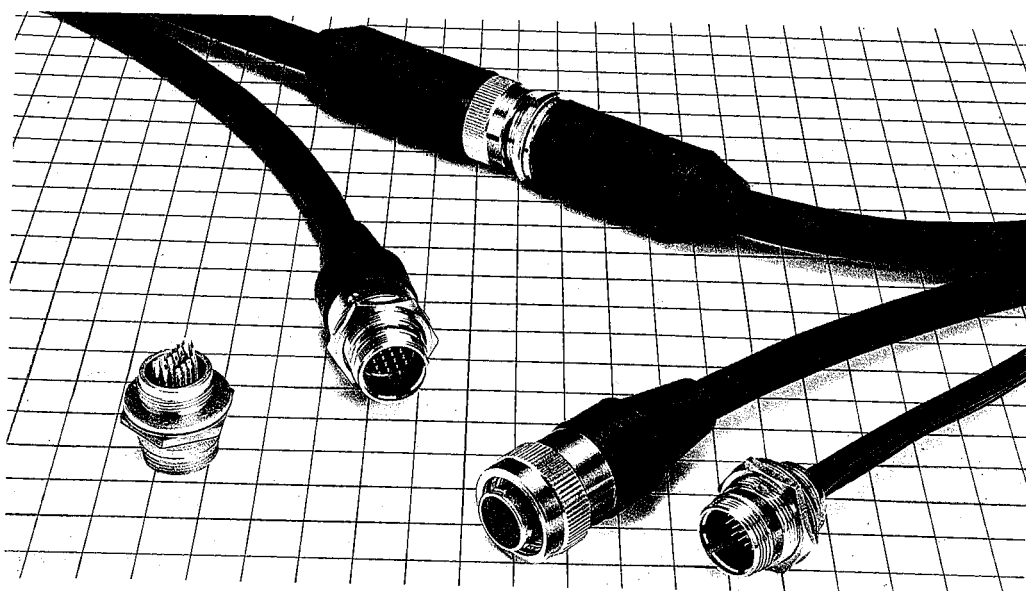

Features

- 1. Available in Waterproof and Non-Waterproof Types.**
Engaged waterproof type connectors are free from water penetration for 48 hours at a depth of 1.8 meters.
- 2. Anti-Loosening Locking Mechanism.**
The locking mechanism has an anti-loosening spring in a screw coupling.
- 3. Two Types of Termination**
Available in two wiring styles for wider selection: Crimp type and soldering.
- 4. Easy Receptacle Mounting.**
A receptacle may be mounted quickly on a panel by tightening a nut.
- 5. Available with Wire Protection**
This type of connector has a shell with a cord bushing for increased cable curvature and protection against wire breakage when bending the wire.
- 6. High-Density Design.**
The maximum plug dia. is 21mm for higher density of a 20-pin type connector.

Application

NC machining tools, FA equipment, communication equipment, measuring instruments and other electronic devices and equipment

■ Materials and Finish

Part No.	Material	Finish
Shell	Zinc alloy and brass	Nickel plating
Insulator	PBT resin ※	(Black)
Male terminal	Brass or phosphor bronze	Silver plating
Female terminal	Beryllium copper or phosphor bronze	Silver plating

※UL94V-0

■ Ordering Information

HR22 - 12 W T P A - 20 SC

-
- (1) Series name
 - (2) Shell size
 - (3) Waterproof/non-waterproof
 - (4) Locking mechanism type
 - (5) Shell type
 - (6) Shell sharp
 - (7) Pins
 - (8) Pin style

- (1) Series name : HR22 Series
- (2) Shell size : This number indicates the outer dia. of the shell of the plug mating part.
- (3) Waterproof/non-waterproof : "W" indicates the waterproof type. No symbol indicates the non-waterproof type.
- (4) Locking mechanism : "T" indicates the screw coupling type.
- (5) Shell type : Shells are divided into the following:
 P : Plug J : Jack R : Receptacle
- (6) Shell sharp : Each time alteration is made to the shell sharp, the symbol changes such as A, B, C, D, E and so forth. Characters C, J, P and R are not used to avoid misunderstanding.
- (7) Pins : Indicates the number of pins.
- (8) Pin style : Indicates the type of pins as follows:
 P : Male pin PC : Crimp type male pin
 S : Female pin SC : Crimp type female pin

■ Plug (Crimp Type)

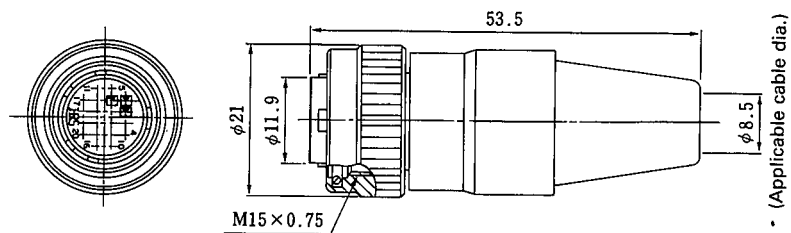
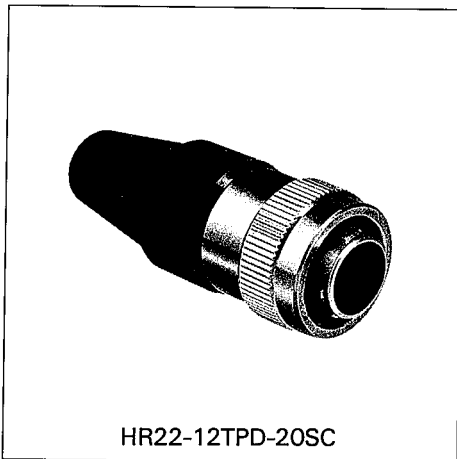

(An example in shape)

HRS No.	Product No.
122-0010-0	HR22-12TPD-20SC
122-0018-1	HR22-12TPD-20PC

■ Jack (Crimp Type)

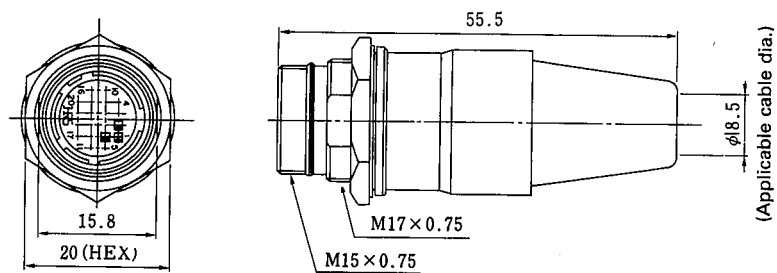

(An example in shape)

HRS No.	Product No.
122-0019-4	HR22-12TJD-20PC

■ Plug (Solder Type)

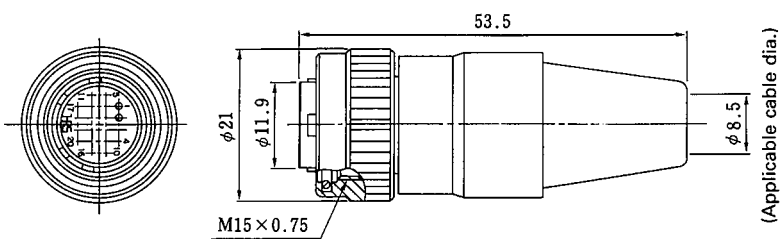
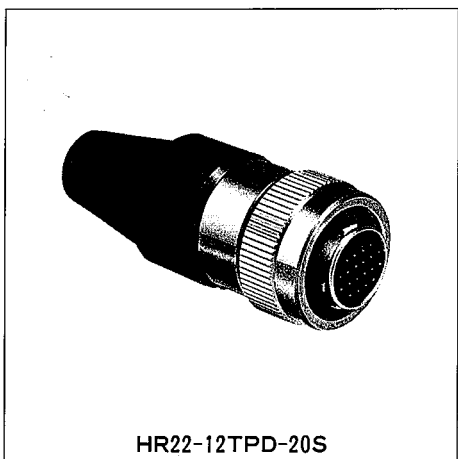

(An example in shape)

HRS No.	Product No.
122-0011-2	HR22-12TPD-20S
122-0012-5	HR22-12TPD-20P

■ Jack (Solder Type)

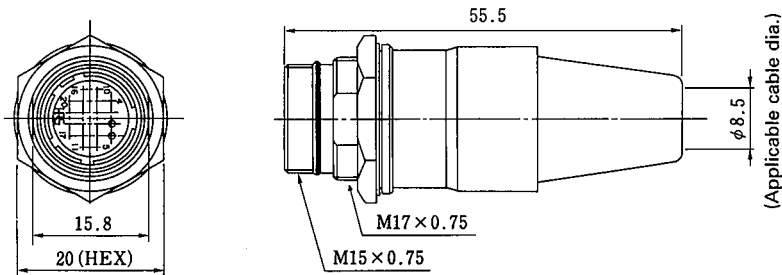

(An example in shape)

HRS No.	Product No.
122-0022-9	HR22-12TJD-20P
122-0023-1	HR22-12TJD-20S

WATERPROOF TYPE

■ Plug (Crimp Type)

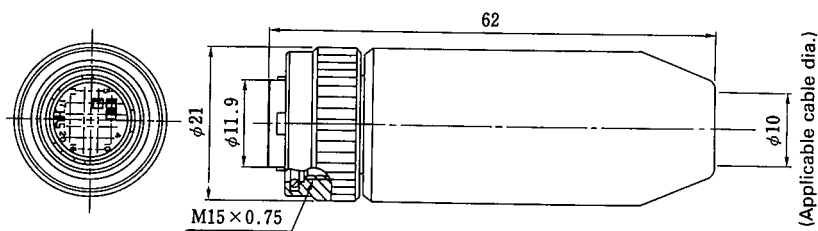
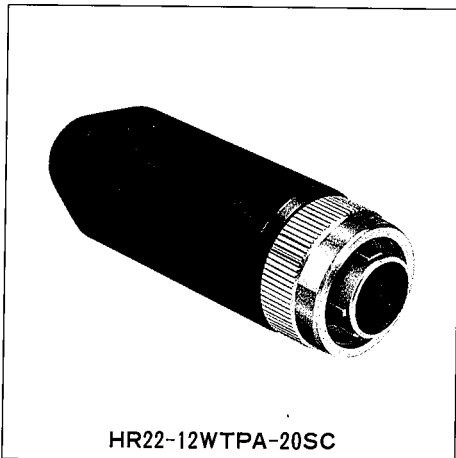

HRS No.	Product No.
122-0004-7	HR22-12WTPA-20SC

■ Receptacle (Crimp Type)

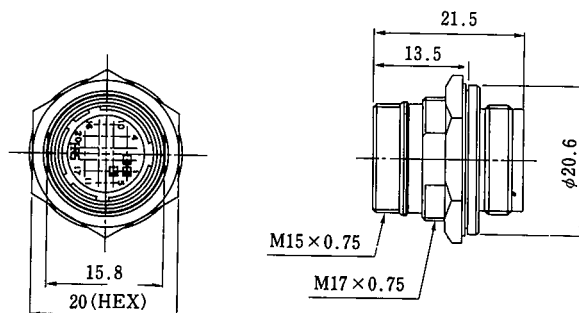
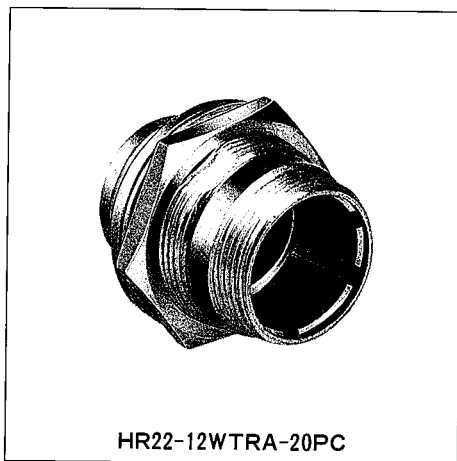

(An example in shape)

HRS No.	Product No.
122-0005-0	HR22-12WTRA-20PC
122-0021-6	HR22-12WTRA-20SC

■ Jack (Crimp Type)

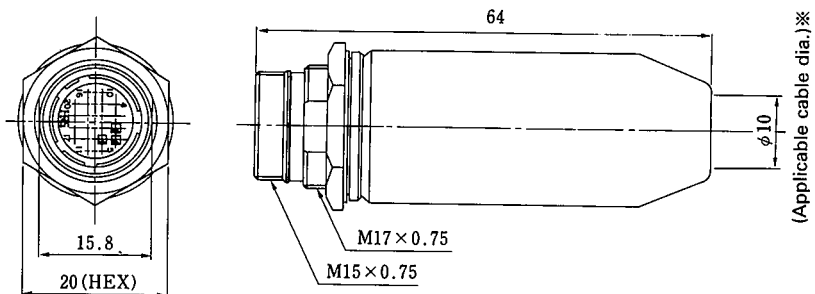

(An example in shape)

HRS No.	Product No.
122-0006-2	HR22-12WTJA-20PC

■ Plug (Solder Type)

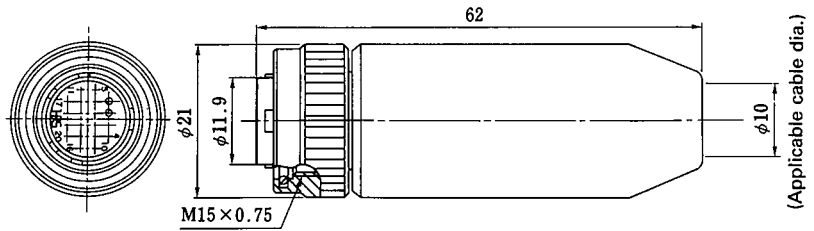
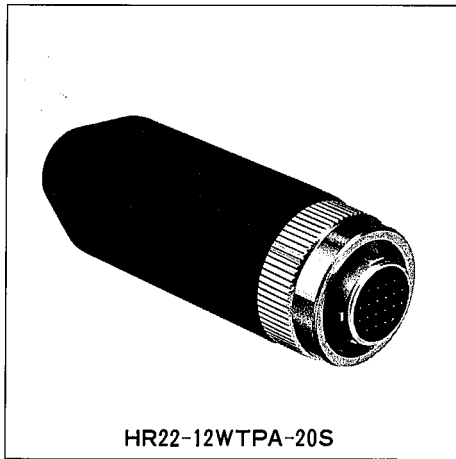

(An example in shape)

HRS No.	Product No.	φ A
122-0015-3	HR22-12WTPA-20S	φ 10
122-0026-0	HR22-12WTPE-20S	φ 9.2

■ Receptacle (Solder type)

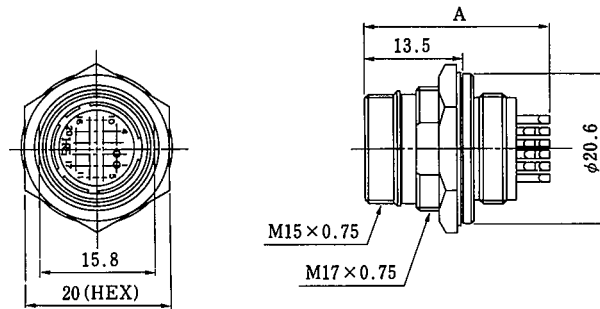

(An example in shape)

HRS No.	Product No.	A
122-0013-8	HR22-12WTRA-20P	25.5
122-0014-0	HR22-12WTRA-20S	24

■ Right angle plug(Solder type)

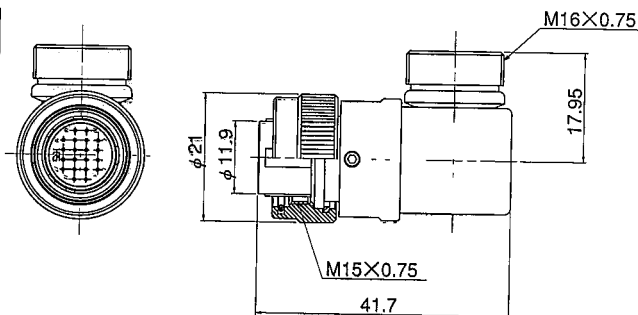
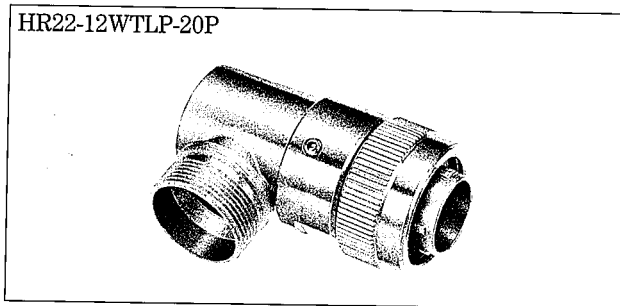

Part Number	HRS No.	Weight
HR22-12WTLP-20P	CL122-0054-5	55g

■ Cable clamp

● Screw tightening type

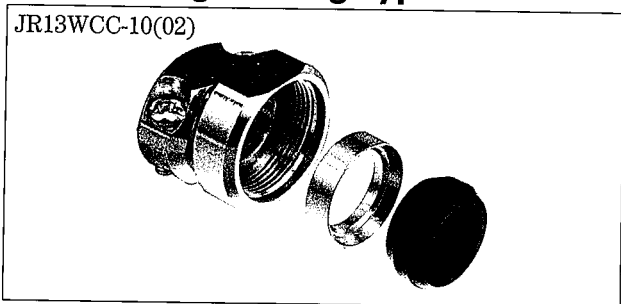

Part Number	HRS No.	A	Weight
JR13WCC-4(02)	CL114-2045-0-02	4	17g
JR13WCC-5(02)	CL114-2046-3-02	5	17g
JR13WCC-6(02)	CL114-2047-6-02	6	17g

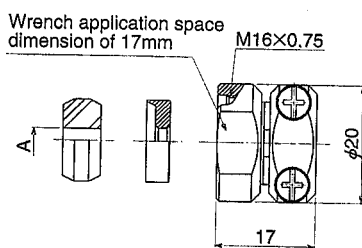

Shown one type

Part Number	HRS No.	A	Weight
JR13WCC-7(02)	CL114-2048-9-02	4	17g
JR13WCC-8(02)	CL114-2049-4-02	5	17g
JR13WCC-9(02)	CL114-2050-0-02	6	17g
JR13WCC-10(02)	CL114-2051-3-02	6	17g

● Without screw type

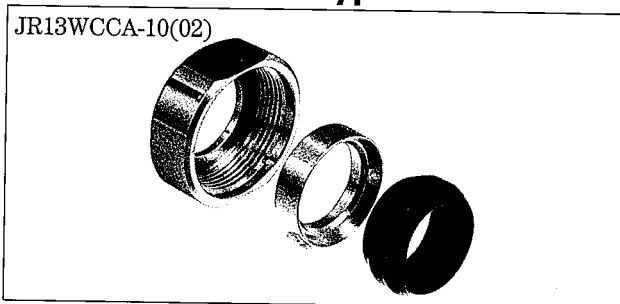

Part Number	HRS No.	A	Weight
JR13WCCA-4(02)	CL114-2069-9-02	4	12g
JR13WCCA-5(02)	CL114-2070-8-02	5	12g
JR13WCCA-6(02)	CL114-2071-0-02	6	12g

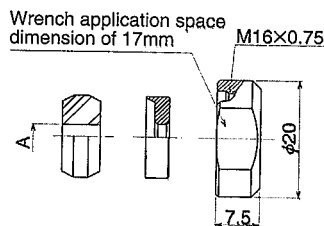

Shown one type

Part Number	HRS No.	A	Weight
JR13WCCA-7(02)	CL114-2072-3-02	4	12g
JR13WCCA-8(02)	CL114-2073-6-02	5	12g
JR13WCCA-9(02)	CL114-2074-9-02	6	12g
JR13WCCA-10(02)	CL114-2075-1-02	6	12g

■ Contact

(Male pin)

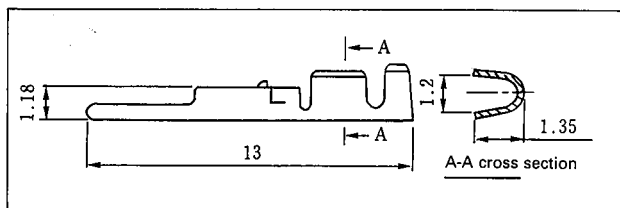

Type	HRS No.	Product No.	Applicable cable
Bulk contact	122-0017-9	HR22-PC-122	AWG #24~#28
Chain contact	122-0009-0	HR22-PC-222	AWG #24~#28

(Female pin)

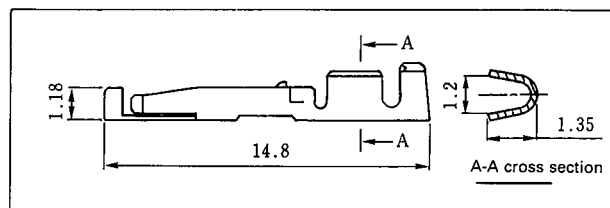

Type	HRS No.	Product No.	Applicable cable
Bulk contact	122-0016-6	HR22-SC-122	AWG #24~#28
Chain contact	122-0008-8	HR22-SC-222	AWG #24~#28

Notes:

- (1) 100 separate terminals are contained in a package. 10,000 continuous terminals are wound on a reel.
- (2) Use a cable having a insulator outer dia. of 1.15 mm or more.

◆ Wiring Jig

A connector may be assembled and disassembled easily using the assembly jig shown below:

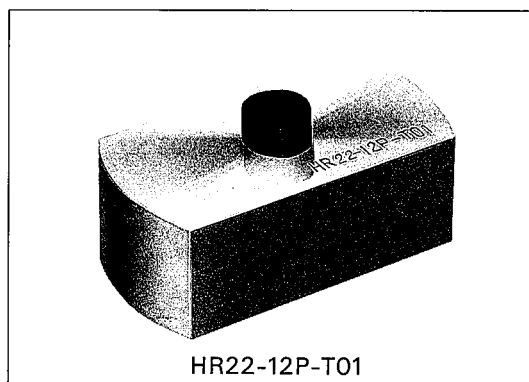

HR22-12P-T01

HRS No.	Product No.	Applicable connector
150-0075-4	HR22-12P-T01	For HR22-12WTPA For HR22-12TPD

◆ Applicable Tools

Type	Item	HRS No.	Part No.	Applicable terminal	Applicable wire
Manual	Manual crimping tool	150-0200-4	HR22-TA2428HC	HR22-PC-122 HR22-SC-122	AWG # 24~# 28
Automatic	Automatic crimping machine body	901-0005-4	CM-105	—	—
	Applicator	901-2023-7	AP105-HR22-2	HR22-PC-222 HR22-SC-222	AWG # 24~# 28
Cable crimping tool		150-0058-5	HR10A-TC-04	—	φ 8.5 (Note)
Extractor		150-0039-0	RP6-SC-TP	—	—
Hexagon bar wrench (opposing side-to-side distance 1.27)		150-0066-3	PB205/1.27	—	—

Note: Cable crimping tools are not used for connecting waterproof connectors.



Manual crimping tool



Pull-out tool

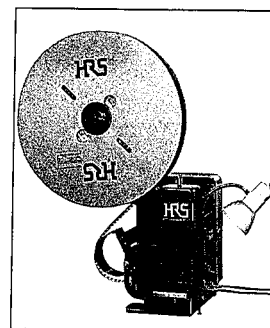

Automatic crimping machine CM-105

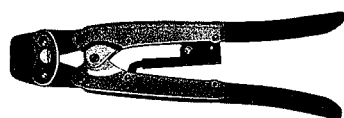

Cable crimping tool



Hexagon wrench driver

◆ Pin Allocation and Major Functions

◆ Panel Mounting Dimensions

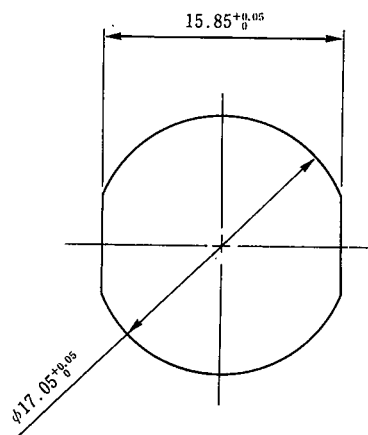

Pin allocation

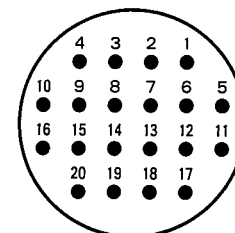

Number of pins	20
Withstand voltage	AC300V for 1 minute
Current capacity	2A
Insulation resistance	1000MΩ or more at DC100V
Contact resistance	20mΩ or less
Solder pot inner dia.	φ 0.8

Notes:

1. The above figure shows the pin allocation viewed from the engagement side.
2. The above withstand voltage shows the test voltage.
3. The above current capacity shows value per pin.
4. The above contact resistance shows value measured at 1A DC.