

**customer manual**

<b>SAFETY PRECAUTIONS</b>	<b>READ THIS FIRST !</b>	2
<b>1. INTRODUCTION</b>		3
<b>2. DESCRIPTION</b>		3
<b>3. RECEIVING INSPECTION AND INSTALLATION</b>		6
3.1. Receiving Inspection		6
3.2. Installation		6
<b>4. OPERATION</b>		6
4.1. Installation and Removal of SDE Tool Head 1763663-2		6
4.2. Installation of Crimping Dies		6
4.3. Terminator Power Supply		8
4.4. Production Operation		8
<b>5. CRIMP HEIGHT ADJUSTMENT</b>		10
<b>6. TROUBLESHOOTING</b>		11
<b>7. MAINTENANCE AND INSPECTION</b>		11
7.1. Cleaning		11
7.2. Visual Inspection		12
7.3. Lubrication		12
7.4. Parts List		12
<b>8. REPLACEMENT AND REPAIR</b>		12
<b>9. CIRCUIT DIAGRAM</b>		13
<b>10. REVISION SUMMARY</b>		13

**DANGER****SAFETY PRECAUTIONS AVOID INJURY**

Safeguards are designed into this application equipment to protect operators and maintenance personnel from most hazards during equipment operation. However, certain safety precautions must be taken by the operator and repair personnel to avoid personal injury, as well as damage to the equipment. For best results, application equipment must be operated in a dry, dust-free environment. Do not operate equipment in a gaseous or hazardous environment.

Carefully observe the following safety precautions before and during operation of the equipment:

- ALWAYS wear appropriate ear protection.
- ALWAYS wear approved eye protection when operating powered equipment.
- ALWAYS keep guard(s) in place during normal operation.
- ALWAYS insert power plug into a properly grounded receptacle to avoid electrical shock.
- ALWAYS turn off the main power switch and disconnect electrical cord from the power source when performing maintenance on the equipment.
- NEVER wear loose clothing or jewelry that may catch in moving parts of the application equipment.
- NEVER insert hands into installed application equipment.
- NEVER alter, modify, or misuse the application equipment.

In addition, keep the following items in mind:

- Handle the terminator with caution and keep out of the reach of children.
- Do NOT remove components such as screws.
- Damage resulting from improper usage void the manufacturer's warranty.
- Terminator cycle is initiated by means of a safety foot pedal which must be held down during the entire cycle. **NOTE:** *The safety lock of the foot pedal disengages when the foot pedal is floored.*
- The terminator is provided with a switch for reverse operation.
- A counter records the number of cycles. A cycle is recorded each time the terminator is switched on or off.
- Two solid wrist supports on the terminator cover help reduce operator fatigue.

**TOOLING ASSISTANCE CENTER**

**CALL TOLL FREE 1-800-722-1111 (CONTINENTAL UNITED STATES AND PUERTO RICO ONLY)**

The **Tooling Assistance Center** offers a means of providing technical assistance when required.

In addition, Field Service Engineers are available to provide assistance in the adjustment or repair of the application equipment when problems arise which your maintenance personnel are unable to correct.

**INFORMATION REQUIRED WHEN CONTACTING THE TOOLING ASSISTANCE CENTER**

When calling the Tooling Assistance Center regarding service to equipment, it is suggested that a person familiar with the device be present with a copy of the manual (and drawings) to receive instructions. When calling the Tooling Assistance Center the following information is required:

1. Customer name
2. Customer address
3. Person to contact (name, title, telephone number, and extension)
4. Person calling
5. Equipment number (and serial number if applicable)
6. Product part number (and serial number if applicable)
7. Urgency of request
8. Nature of problem
9. Description of inoperative component(s)
10. Additional information/comments that may be helpful

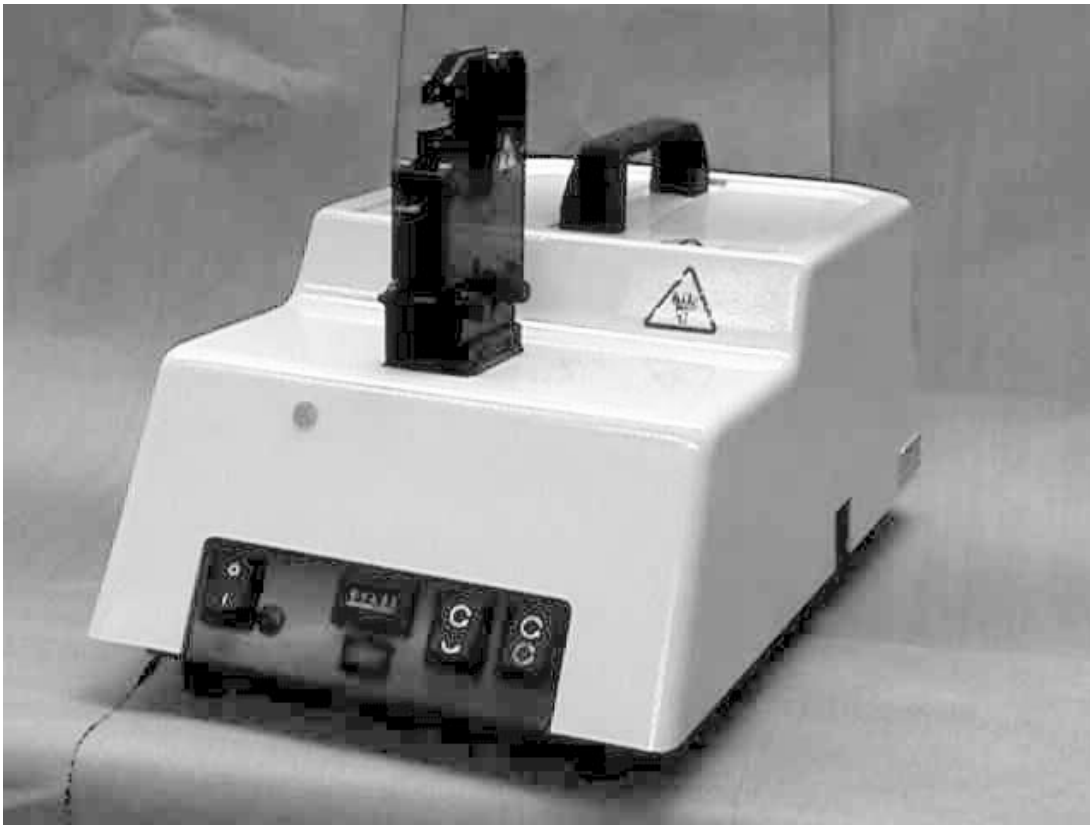

Figure 1

## 1. INTRODUCTION

These instructions contain operation and setup procedures for the SDE Electric Bench Terminator 1490076-2. This terminator has been manufactured in accordance with DIN EN ISO 9001.

When reading this manual, pay particular attention to **DANGER**, **CAUTION**, and **NOTE** statements.

**DANGER**

*Denotes an imminent hazard which may result in moderate or severe injury.*

**CAUTION**

*Denotes a condition which may result in product or equipment damage.*

**NOTE**

*Highlights special or important information.*

**NOTE**

*Dimensions in this manual are in metric units [with U.S. customary units in brackets].*

Read and understand these instructions completely before attempting to operate the terminator.

## 2. DESCRIPTION

This terminator is equipped with a holder for tool heads, allowing a quick installation and removal of the various tool heads. The terminator is activated by means of a foot pedal which must be operated during the entire work cycle to meet all CE-safety requirements.

A further safety component is a safety lock on the foot pedal. The ergonomic design of the foot pedal cover supports the foot of the operator. The sturdy workmanship of the unit is designed for long lasting performance.

Specifications for SDE Electric Bench Terminator 1490076-2 are contained in Figure 2.

<b>SPECIFICATIONS</b>	
Dimensions:	390mm X 260mm X 200mm [15.5 in. X 10 in. X 8 in.]
Weight::	13kg [ 29 lbs]
Power Requirements:	220 Vac / 240 Vac, 50/60 Hz -- 110 Vac / 120 Vac, 60 Hz
Power Consumption:	.7 KVA Max.

*Figure 2*

Identification of items on SDE Electric Bench Terminator 1490076-2 can be found in Figure 3.

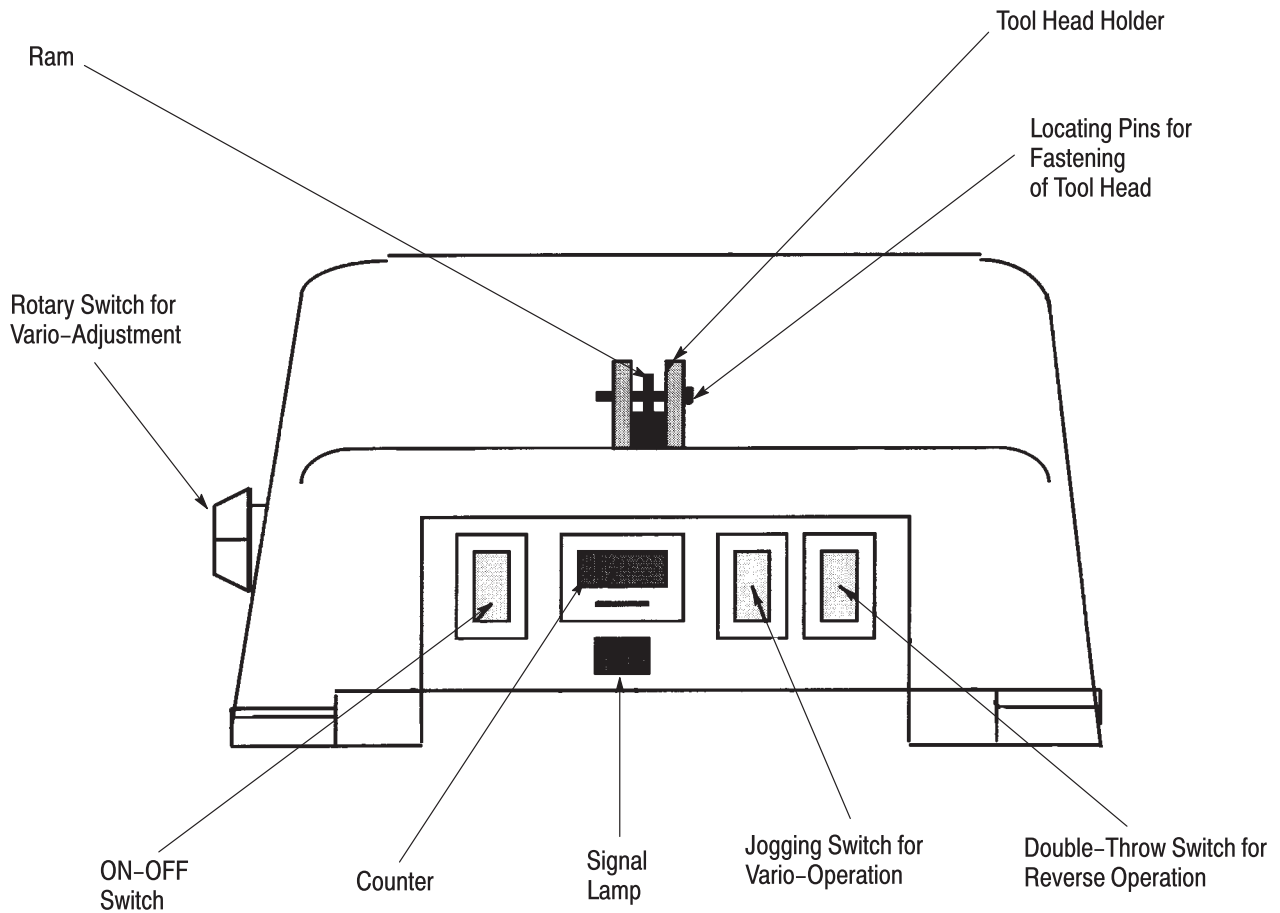

*Figure 3*

An identification of the front panel controls can be seen in Figure 4.

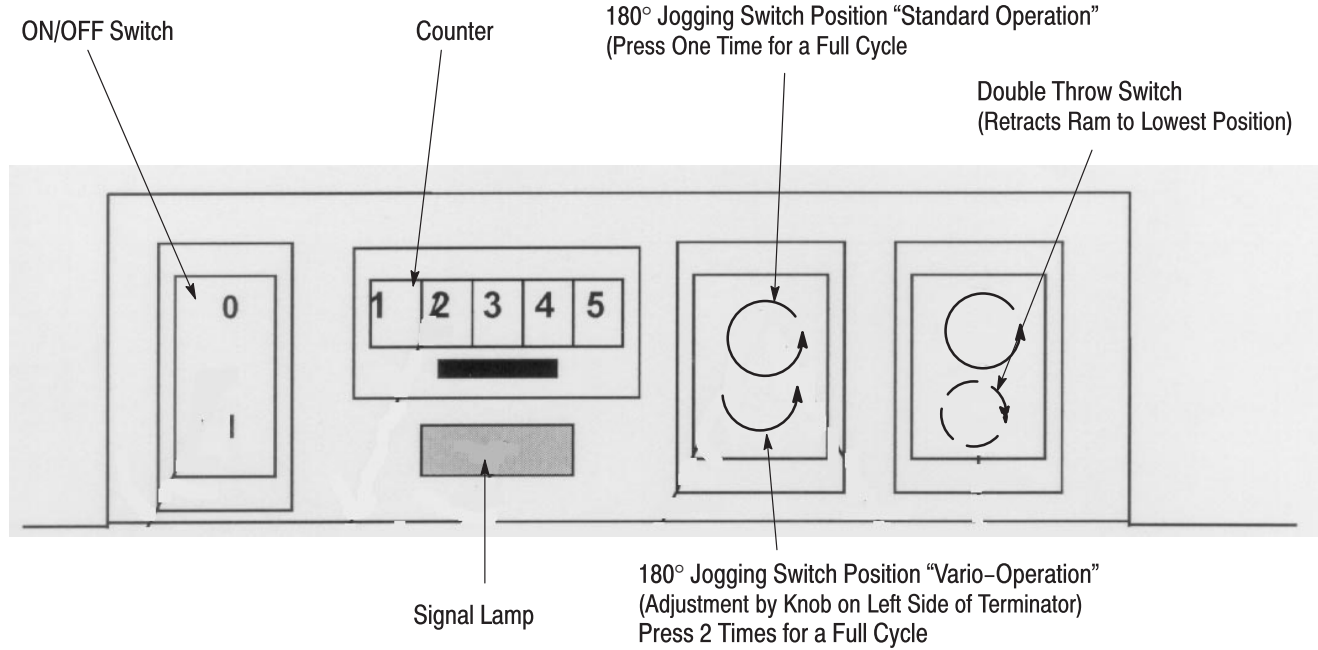

Figure 4

An identification of the rear mounted controls can be seen in Figure 5.

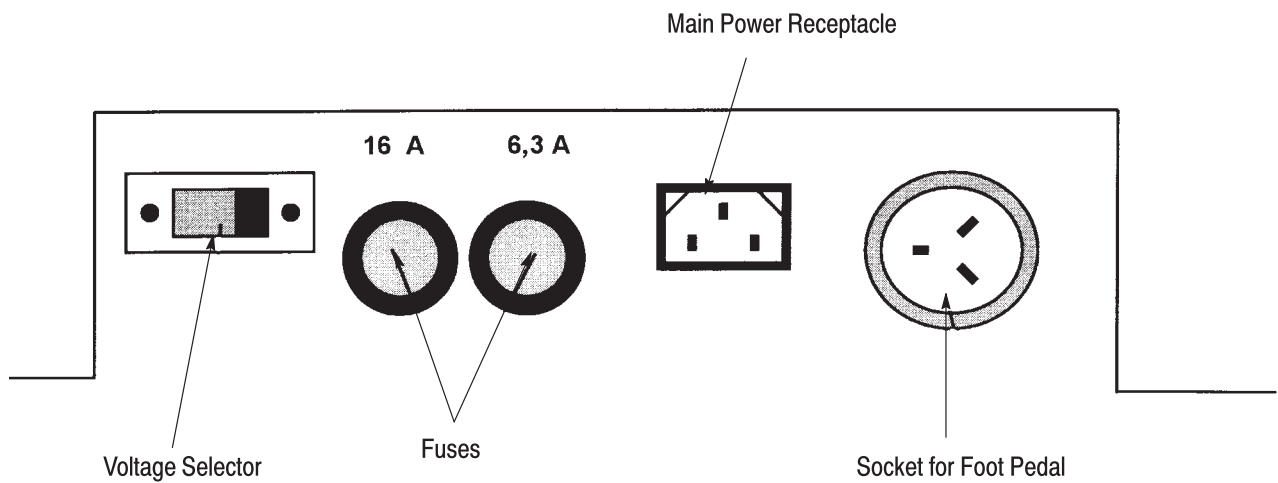

Figure 5

### 3. RECEIVING/INSPECTION AND INSTALLATION

#### 3.1. Receiving/Inspection

The SDE Electric Bench Terminator 1490076-2 is thoroughly inspected during and after assembly. Prior to packaging and shipping, a final series of tests and inspections is made to ensure proper functioning of the terminator. The following inspection should be performed as a safeguard against potential problems generated in transit.

**NOTE**

*The components of the terminator are packaged so that they can be removed from the packaging and immediately installed, as described in Paragraph 3.2.*

1. In a well-lighted area, carefully uncrate the terminator and inspect each component as it is removed from the crate.
2. Thoroughly inspect each component for evidence of damage that may have occurred in transit. If any of the components are damaged, file a claim against the carrier and notify Tyco Electronics immediately.
3. Inspect all electrical lines for evidence of damage.

**NOTE**

*It is important that this manual and other documents (such as drawings and parts lists), as well as any enclosed product samples, remain with the terminator for the benefit of personnel responsible for installation, operation, and maintenance.*

#### 3.2. Installation

Place the SDE Electric Bench Terminator 1490076-2 on a well lit desktop. Plug the electrical cord into the electrical outlet (refer to Figure 2 for power requirements, and Paragraph 4.4,A for instructions on plugging the cord into the outlet).

If required, secure the terminator to the bench.

### 4. OPERATION

**DANGER**

*To avoid personal injury, do not cycle the SDE Electric Bench Terminator without the tool head installed.*

#### 4.1. Installation and Removal of SDE Tool Head 1673663-2

##### A. Installation

Before mounting the SDE tool head, always make sure that the guide ram of the terminator is in the lowest position. (Refer to Figure 6.)

**DANGER**

*To avoid personal injury, be sure the SDE Electric Bench Terminator is disconnected from the power source prior to the installation or removal of the tool head.*

1. Be sure that the terminator has been switched off.
2. Be sure that the SDE tool head is mounted with opening for the dies in the front, to facilitate die installation and removal.
3. Mount the head from the back and lock with the safety pins. (Refer to Figures 7 and 8.)
4. Refer to Paragraph 4.2, to remove and install the crimping dies.

##### B. Removal

**DANGER**

*To avoid personal injury, be sure the SDE Electric Bench Terminator is disconnected from the power source prior to the installation or removal of the tool head.*

1. Be sure the terminator has been switched "off."
2. Remove the locating pins from the tool holder.
3. Remove and/or replace the tool head.
4. When removing the tool head, make sure that the guide ram of the terminator is in the lowest position.
5. If installing or removing crimping dies, refer to Paragraph 4.2.

#### 4.2. Installation of Crimping Dies

**DANGER**

*To avoid personal injury, be sure the SDE Electric Bench Terminator is disconnected from the power source prior to the installation or removal of the crimping dies.*

Guide Ram

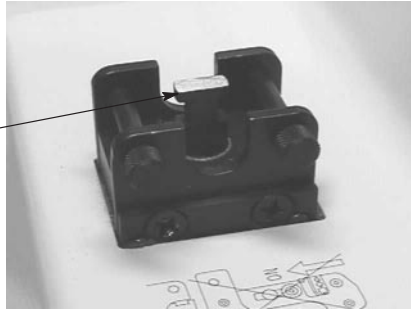

Figure 6

Control Lever



Tool Head

Figure 7

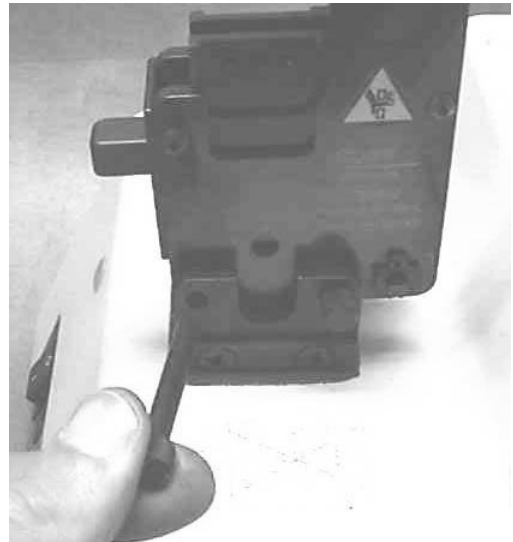
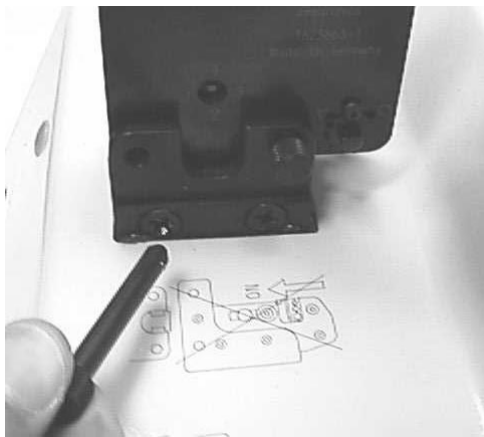

Figure 8

**CAUTION**

*These instructions are specific to the use of Tyco Electronics SDE crimping dies. BE SURE to use only Tyco Electronics crimping dies.*

**A. Installation of Shouldered Dies**

1. Remove the two die retaining screws from the tool head.

**NOTE**

*Be sure to keep the die retaining screws. They WILL be required to install shouldered dies.*

2. Depress the control lever to open the tool head and place the upper die in the upper jaw of the tool head so that the largest indenter is facing inward.
3. Insert the die retaining screw through the upper jaw and through the die. Tighten the screw *just enough* to hold the die in place. Do *NOT* tighten the screw completely at this time.
4. Place the lower die in the moving jaw of the tool head so that the largest anvil is facing inward.
5. Insert the die retaining screw through the lower jaw and through the die. Tighten the screw *just enough* to hold the die in place. Do *NOT* tighten the screw completely at this time.
6. Release the control lever to close the tool head, making sure the anvils and indenters align properly. Hold the tool head closed to keep the dies in place, and then tighten both retaining screws.
7. To disassemble, open the tool head, remove the two die retaining screws, and slide the dies out of the tool head.

**B. Installation of Pinned Dies**

1. Remove the two die retaining screws from the tool head.

**NOTE**

*Be sure to keep the die retaining screws. Although they will not be required to install pinned dies, you may need them for future use.*

2. Depress the control lever to open the head and install the anvil die into the moving jaw of the tool head. The die assembly should be oriented so that the chamfers are positioned toward the front of the head assembly, and the die markings are facing outward.
3. Insert two die retaining pins and the short die retaining screw into the moving jaw and through the anvil die. Tighten the screw just enough to hold the die in place. Do *NOT* completely tighten the screw at this time.
4. Install the crimper die into the upper crimping upper crimping jaw of the tool head. The die should be oriented so that the chamfers are positioned toward the front of the head assembly and the die markings are facing outward.
5. Insert two die retaining pins and the long die retaining screw into the upper jaw and through the the crimper die. Tighten the screw just enough to hold the die in place.
6. Check the die alignment by releasing the control lever to close the tool head, making sure the anvil and indeter align properly. When the dies are properly aligned, fully tighten the the die retaining screws.
7. Install the locator assembly onto the long retaining screw and secure it with the appropriate hex nut.
8. To remove the dies from the tool head, open the tool head, remove the die retaining pins and screws, and slide the dies out of the tool head.

**4.3. Terminator Power Supply**

The terminator can be operated with 220/240 Vac *or* 110/120 Vac. The voltage selector is located at the rear side of the terminator. The terminator is set

**NOTE**

*The terminator is set by the manufacturer at 220/240 Vac.*

**4.4. Operation****DANGER**

*To avoid personal injury, keep fingers clear of the crimp dies when operating the tool. Never place anything in the crimping dies but terminals and splices.*



## A. Normal Production Operation

This procedure assumes that the tool head and dies have been installed.

1. Connect the provided power cord into the receptacle at the rear of the terminator, and then into the power outlet.
2. Move the ON/OFF button to Position No. "1".

The green signal lamp should light when the ON/OFF switch is in Position No. "1". If the signal lamp does *not* light, check the fuses at the rear of the terminator. These fuses can be checked after rotating and removing the the back fuse holders.

3. Connect the foot pedal to the foot pedal socket at the rear of the terminator. Lock the pedal in place by turning the connector clockwise.

The foot pedal is equipped with a safety lock, which prevents operation of the terminator when the foot pedal has been completely floored due to excessive pressure applied to the foot pedal.. This safety lock can be released by turning the knob on the foot pedal back to its original position. Now the terminator is ready for operation again.

### NOTE

*The dies are normally closed, for safety reasons. The dies are opened (retracted) with the control lever at the front of the tool head in order to insert the connector to be crimped.*

4. After the connector is properly positioned in the crimp dies, release the control lever to allow the dies to spring shut, holding the connector in position.
5. Insert the stripped wire, then apply moderate pressure to the foot pedal to cycle the terminator.

### NOTE

*The foot pedal must be held down constantly to ensure a complete working cycle.*

6. Open the dies by depressing the control lever, and remove the completed crimp.

## B. Vario-Operation (Figure 9)

The terminator can be operated also in "double step" mode. When the terminator has been switched to Vario-operation, it can be operated with two separate and distinct steps: First step for holding the inserted contact, second step for crimping and moving back into the final position.

The Vario-position can be adjusted to the respective contact material (1 = min; 6 = max.) by means of the knob for Vario-adjustment (refer to Figure 3).

## C. Reverse Rocker Switch

If it is necessary to retract the dies without completing the crimping cycle, depress and hold the reverse rocker switch to return the guide ram of the tool head to the lowest position.

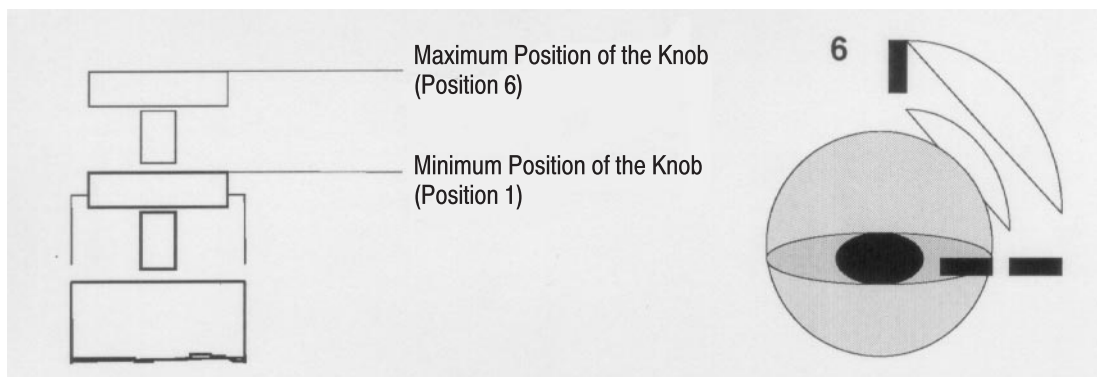

Figure 9

### 5. CRIMP HEIGHT ADJUSTMENT

Crimp height adjustment is required only if the crimp height listed in the Tyco Electronics die specification is not achieved.

Adjust the crimp height with a flat-bladed screwdriver.

There are four different crimp heights. Refer to Figure 10.

**NOTE** Although Tyco Electronics normally recommends Position No. 2 (adjustment of the manufacturer), Positions No. 3 and No. 4 increase the travel of the tool head, which decreases the crimp height. Position No. 1 decreases the travel of the head, which increases the crimp height.

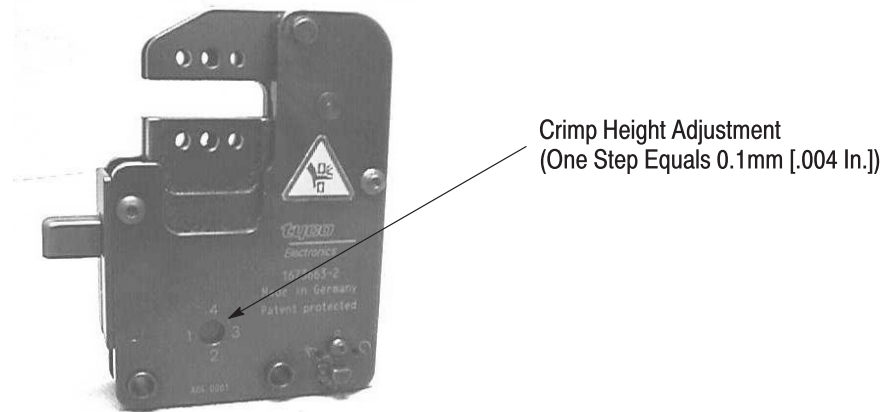

Figure 10

**6. TROUBLESHOOTING**

Refer to Figure 11 for troubleshooting information.

PROBLEM	ACTION	
Signal lamp doesn't light	Check correct position of connecting cable	
	ON/OFF switch in Position "I"?	
	Inspect fuses	
Terminator cannot be operated	Power supply o.k.? Signal lamp lights up?	
	Foot pedal correctly connected?	
	Foot pedal locked in?	
	Release the safety lock by turning knob..	
Terminator performs only a half cycle	180° Jogging switch in "Vario" position. Switch it to "Standard."	
Tool head cannot be installed in holder	Terminator not in final position	180° Jogging-switch in "Vario" position!
		Switch to "Standard" and try again
	Tool head not in final position!	Move the device to start position by means of the double throw switch
		Move crimp anvil to lowest position (see the instruction sheet of the appropriate tool head)
Tool head ram doesn't engage correctly in terminator ram	Refer to Paragraph 4.1, Installation/Removal of the Tool Head	
Tool head doesn't open	Move the terminator stepwise back by means of the double throw switch	
	Clean and lubricate tool head in the crimp area and inspect for damages	
	<b>CAUTION:</b> Never use a damaged tool!	
Tool head cannot be removed	Tool head is under preload	
	Move back stepwise by means of the double-throw switch until tool head can be removed.	

Figure 11

**7. MAINTENANCE AND INSPECTION**

**DANGER** To avoid personal injury, ALWAYS disconnect the SDE Electric Bench Terminator before performing any maintenance or inspection.

Tyco Electronics recommends that a maintenance and inspection program be performed periodically to ensure dependable and uniform terminations. The SDE Electric Bench Terminator should be inspected monthly. Frequency of inspection should be adjusted to suit your requirements through experience. Frequency of inspection depends on:

- The care, amount of use, and handling of the terminator.
- The type and size of the product crimped.
- The degree of operator skill.
- The presence of abnormal amounts of dust or dirt.
- Your own established standards.

It is recommended that all moving parts (particularly the movable driving parts) of the tool be lubricated from time to time. Lubrication not only keeps the tooling operating efficiently, it protects the tooling from humidity.

**NOTE** For die closure inspections and plug gage dimensions, as well as inspections of the crimp areas, and crimping die maintenance, refer to the appropriate die assembly instruction sheet.

**7.1. Cleaning**

Remove dust, moisture, and other contaminants with a clean soft brush, or a soft, lint-free cloth. Do NOT use objects or cleaning materials that could damage tooling. Re-lubricate the sliding surfaces of the head assembly as described in Paragraph 6.3 before placing the head back into service.

**7.2. Visual Inspection**

1. Inspect the tool head assembly for missing heads or screws. Check all movable drive parts and tool head surfaces for wear.
2. Inspect the crimp areas in the die assembly for flattened, chipped, or broken areas. Although the dies may gage within permissible limits, worn or damaged die closure surfaces may affect the quality of the crimp.

**7.3. Lubrication**

Lubricate all movable driving parts with a high quality grease. Tyco Electronics recommends the use of Molycote paste (which is a commercially available lubricant). Lubricate according to the following schedule:

- Lubricate the head assembly used in daily production on a daily basis
- Lubricate the head assembly (used occasionally) in daily production on a weekly basis
- Lubricate the head assembly used weekly on a monthly basis

Wipe the excess grease from the head assembly, particularly in the die closure areas. The grease transferred from the die closure die closure area onto certain terminations may affect the electrical characteristics of a termination.

**7.4. Parts List**

Figure 12 contains a basic parts list for the SDE Electric Bench Terminator.

**8. REPLACEMENT AND REPAIR**

Basic replacement parts are listed in Paragraph 7.4. Parts SHOULD be replaced by Tyco Electronics to ensure quality and reliability of the head assembly and terminator. Order replacement parts through your Tyco Electronics Representative, or call 1-800-526-5142, or send a facsimile of your purchase order to 1-717-986-7605, or write to:

CUSTOMER SERVICE (38-35)  
 TYCO ELECTRONICS CORPORATION  
 P.O. BOX 3608  
 HARRISBURG, PA 17105 – 3608

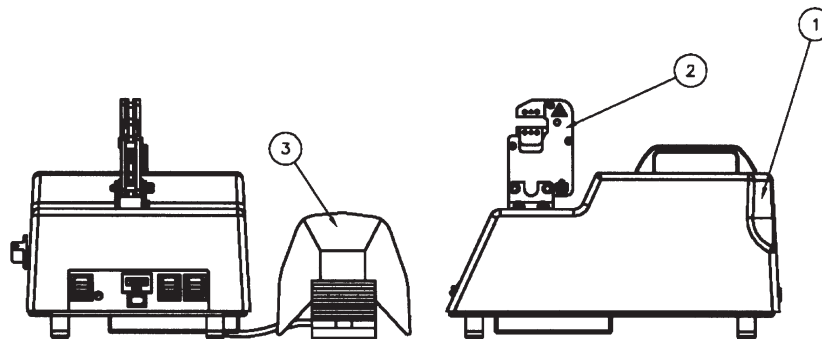

ITEM	DESCRIPTION	PART NUMBER
1	SDE Electric Bench Terminator	1673677-1
2	Head, SDE Electric Bench Terminator	1673663-2
3	Foot Pedal	1673664-1

Figure 12

9. CIRCUIT DIAGRAM

Figure 13 contains the terminator circuit diagram.

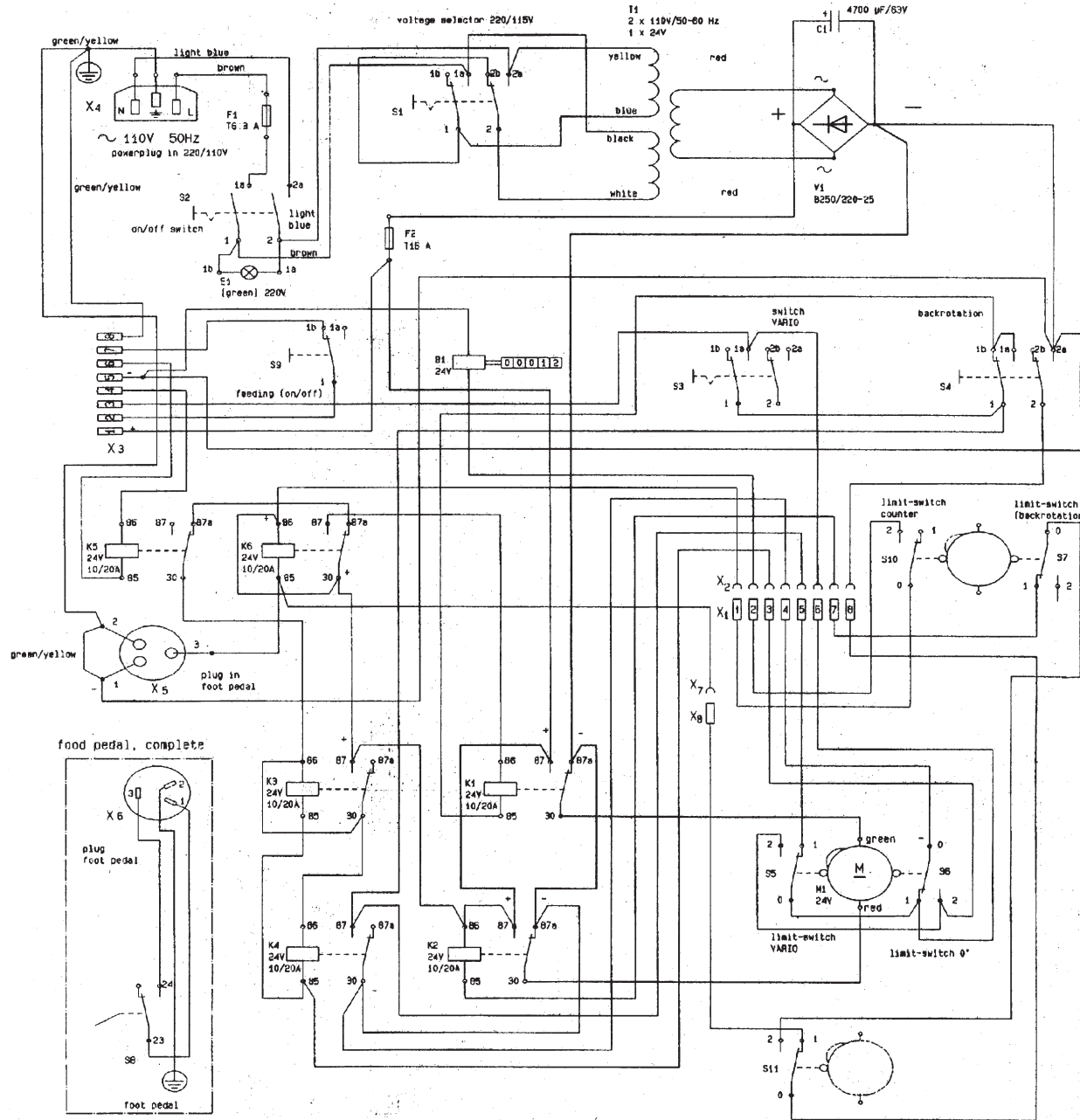

Figure 13

10. REVISION SUMMARY

- The first paragraph in Section 5 was corrected.
- The document format was updated to the current corporate requirements