

# 1mm Pitch Cable-to-Board Connectors supporting LVDS signal

## FX15 Series

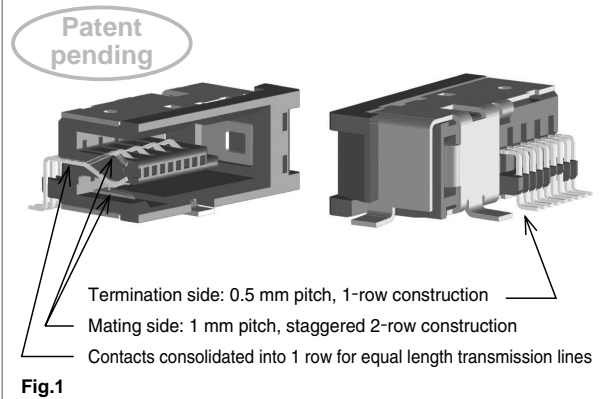

### Space saving, Equal length transmission lines



### ■ Features

#### 1. Space saving

Reduction in space is achieved by designing the contacts in 2-row staggered 1 mm pitch on the mating side and on a single row 0.5 mm pitch on the termination side (Fig. 1).

#### 2. Equal length transmission lines

Contact configuration creates equal length transmission lines preventing deterioration of LVDS signal within the connector (Fig.1).

#### 3. Different types

Availability of types with or without metal shields allows flexibility of applications and cost reduction.

#### 4. Self alignment and self-guiding

Built-in guide posts allow secure self-alignment within  $\pm 1.5$  mm (Fig.2).

#### 5. Secure and complete mating / unmating

Side latch-locks assure and confirm complete and secure mating of plugs to receptacles while permitting ease of disconnection (Fig. 3).

#### 6. Enhanced shielding effectiveness

Availability of version with enlarged metal shields (preventing intrusion or emission of the electromagnetic interference) further protects the integrity of LVDS signal (FX15S series, Fig.4)

#### 7. RoHS compliant

All components and materials comply with the requirements of EU Directive 2002/95/EC.

### ■ Applications

FPD-TV, FPD panels and other applications requiring secure and reliable connection and transmission signal integrity.

### Self-alignment of $\pm 1.5$ mm

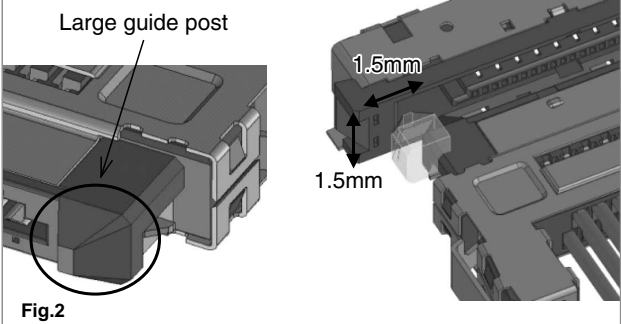

### Side latch -locks

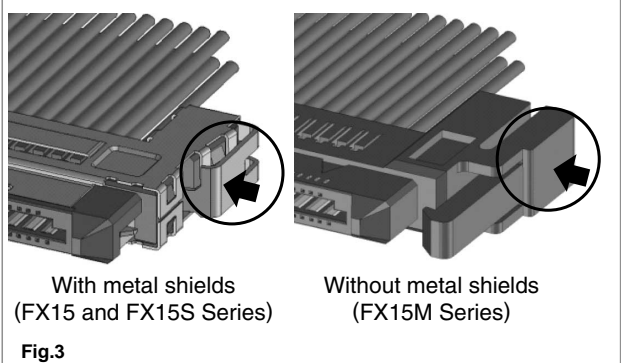

### High Shielding Effectiveness

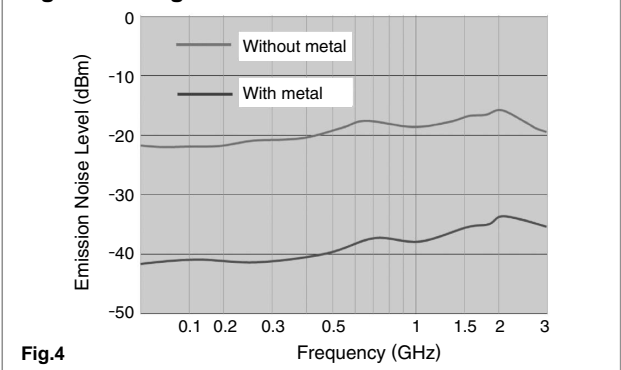

## FX15 Series • 1mm Pitch Cable-to-Board Connectors Supporting LVDS signal

### Product Specifications

Ratings	Current rating Voltage rating	0.5A 100V AC	Operating temperature range Storage temperature range	-55°C to +80°C (Note 1) -10°C to +60°C (Note 2)
---------	----------------------------------	-----------------	--	--

Item	Specification	Conditions
1. Contact resistance	60 m ohms max. (Note 3)	1 mA
2. Insulation resistance	500 M ohms min.	100V DC
3. Withstanding voltage	No flashover or insulation breakdown.	300V AC/one minute
4. Insertion-Extraction force	0.2N min., 30N max.	With corresponding connector
5. Durability (mating/un-mating)	Contact resistance: 80 m ohms max.(Note 3)	50 cycles
6. Vibration	No electrical discontinuity of 1 μs or more.	Frequency: 10 to 55 Hz, single amplitude of 0.76mm, 2 hours, 3 axis
7. Shock	No electrical discontinuity of 1 μs or more.	Acceleration of 490m/s <sup>2</sup> , 11ms durations, sine half-wave waveform, 3 cycles, 3axis.
8. Humidity	Contact resistance: 80 m ohms max. No damage, cracks, or parts dislocation.(Note 3)	96 hours at 40°C, RH 90% to 95%
9. Temperature cycle	Contact resistance: 80 m ohms max. (Note 3) Insulation resistance: 500 M ohms min.	Temperature : -55°C → +15°C to +35°C → +85°C → +15°C to +35°C Time : 30 → 5 → 30 → 5 (Minutes) 5 cycles
10. Salt spray	Contact resistance: 80 m ohms max. (Note 3) No corrosions	5% water solution for 48 hours.

Note 1: Includes temperature rise caused by current flow.

Note 2: The term "storage" refers to products stored for long period of time prior to mounting and use. Operating temperature range and humidity range covers non-conducting condition of installed connectors in storage, shipment or during transportation.

Note 3: Includes wire conductor resistance (12mm long).

Note 4: Information contained in this catalog represents general requirements for this Series. Contact us for the drawings and specifications for a specific part number shown.

### Materials and Finishes

#### ●Receptacle

Component	Material	Finish	Remarks
Insulator	Polyamide	Color: Black	UL94V-0
Contact	Phosphor bronze	Contact area: Gold plated Termination area: Tin plated	_____
Metal shields (with shields)	FX15S : Nickel silver FX15SC : Stainless steel	FX15S : _____ FX15SC : Tin plated	_____
Metal fittings (without shields)	Phosphor bronze	Selective gold flash plated	_____

#### ●Plug

Component	Material	Finish	Remarks
Insulator	Polyamide	Color: Black	UL94V-0
Contact	Phosphor bronze	Contact area: Gold plated Termination area: Tin plated	_____
Metal shields (with shields)	Nickel silver	_____	_____
Metal latch-locks (with shields)	Stainless steel	_____	_____
Metal shields, metal latch-locks (micro-coaxial cable)	Stainless steel	Nickel plated	_____

### Ordering information

#### ●Receptacle

**FX15 S - 31 S - 0.5 SH**  
 ① ② ③ ④ ⑤ ⑥

#### ●Plug

**FX15 S - 31 P - C**  
 ① ② ③ ④ ⑦

#### ●Crimp contact

**FX15 - 3032 PCF B**  
 ① ⑧ ⑨ ⑩

① Series Name	: FX15
② Configuration	Blank : With shields (or crimp contact) 15S : With shields – enhanced shielding 15SC : With shields – enhanced shielding (PCB mounting pattern : VESA standard) 15M : Without shields
③ Number of contacts	
④ Connector type	P : Male contact S : Female contact
⑤ Contact pitch	: 0.5 mm
⑥ Housing configuration	SH : Right angle SV : Straight
⑦ Termination	C : Crimp 0.5SD : Micro-coaxial cable GND : Separate ground plate
⑧ Applicable conductor	2830 : AWG 28 to 30 3032 : AWG 30 to 32
⑨ Packaging	PCF : Reel/ plug contact
⑩ Plating (contact area)	B : Gold plated

## ■FX15 Series – Mating Diagram

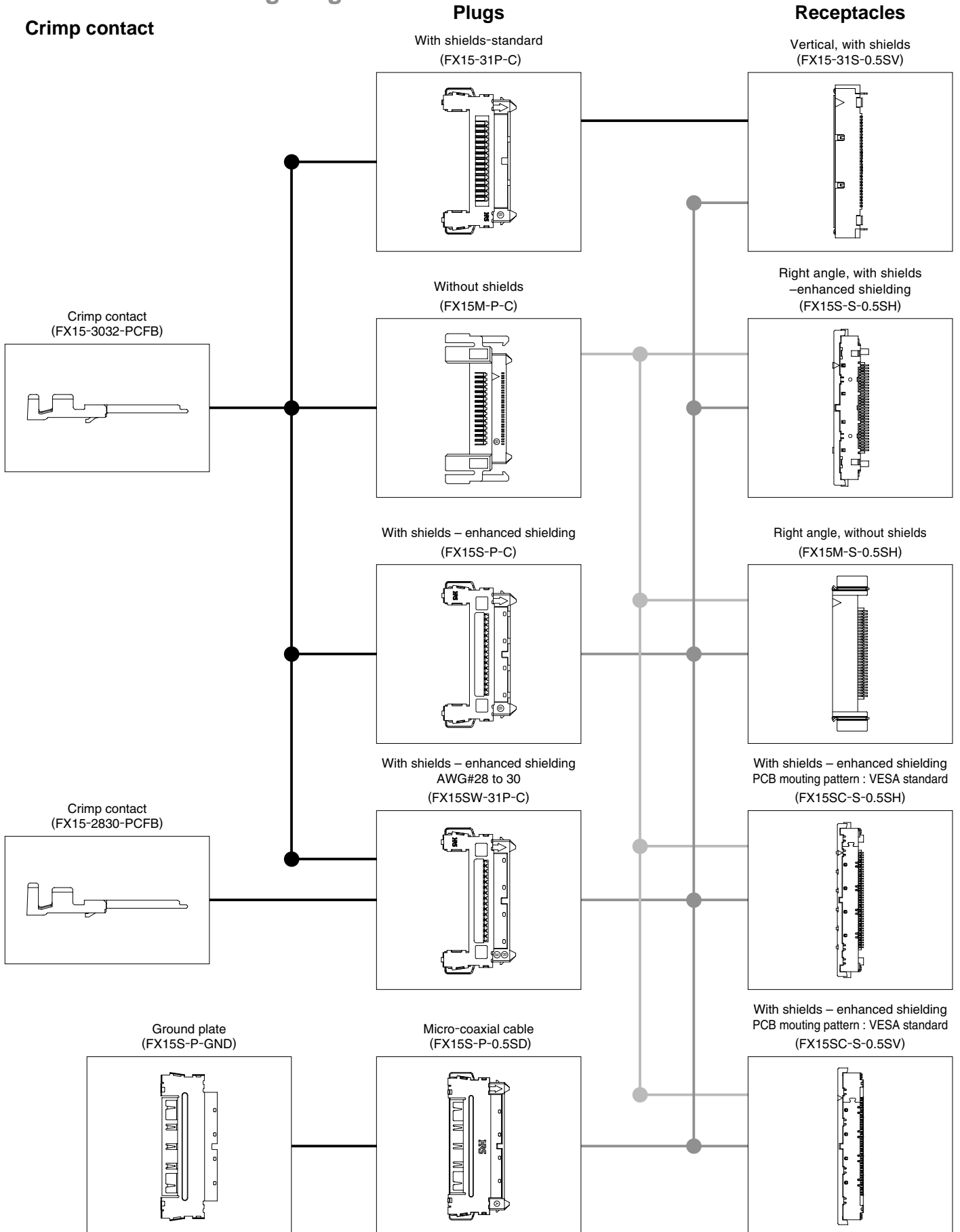

Regarding the availability of the positions, contact your nearest Hirose representative.

FX15 Series 1mm Pitch Cable-to-Board Connectors Supporting LVDS signal

## Plugs

### With shields (FX15-31P-C)

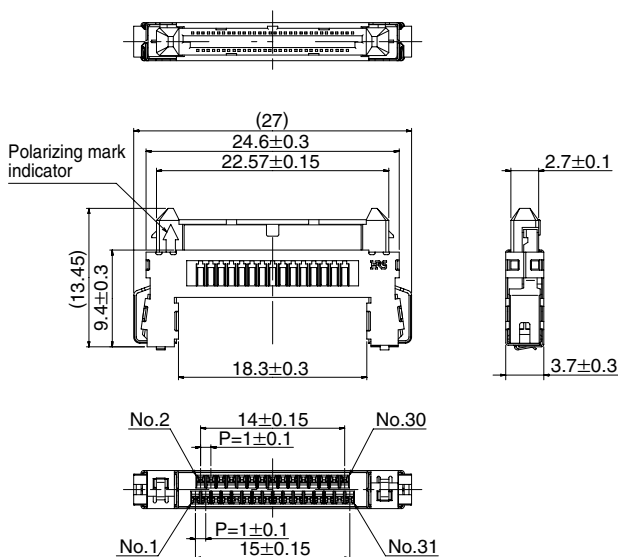
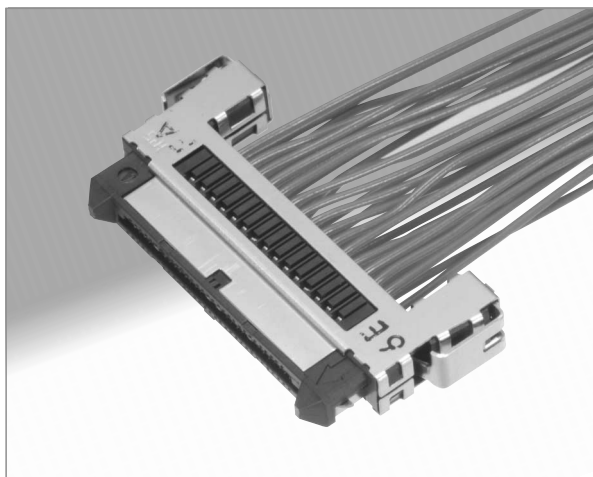

Part number	CL No.	Number of contacts	RoHS
FX15-31P-C	CL575-2101-2	31	YES

Note 1: Packaged in trays.

Note 2: Dimensions in parenthesis ( ) are reference dimensions.

### With shields, enhanced shielding (FX15S-\*\*\*P-C)

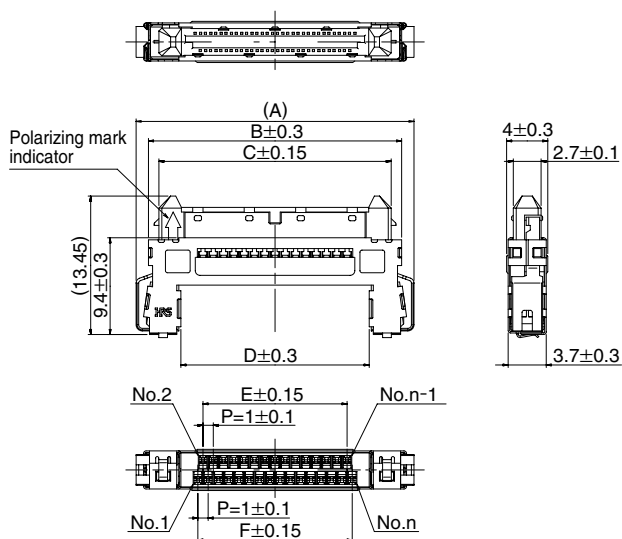
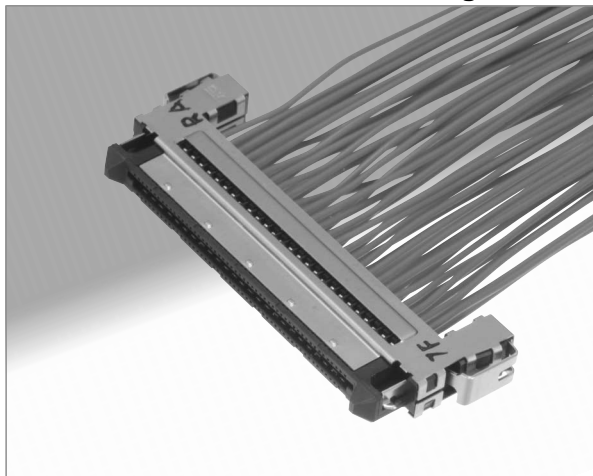

Part number	CL No.	Number of contacts	A	B	C	D	E	F	RoHS
FX15S-31P-C	CL575-2106-6	31	27	24.6	22.6	18.3	14	15	YES
FX15S-41P-C	CL575-2107-9	41	32	29.6	27.6	23.3	19	20	
FX15S-51P-C	CL575-2103-8	51	37	34.6	32.6	28.3	24	25	

Note 1: Packaged in trays.

Note 2: Dimensions in parenthesis ( ) are reference dimensions.

FX15 Series 1mm Pitch Cable-to-Board Connectors supporting LVDS signal

●With shields – enhanced shielding  
 AWG#28 to 30 (FX15SW-31P-C)

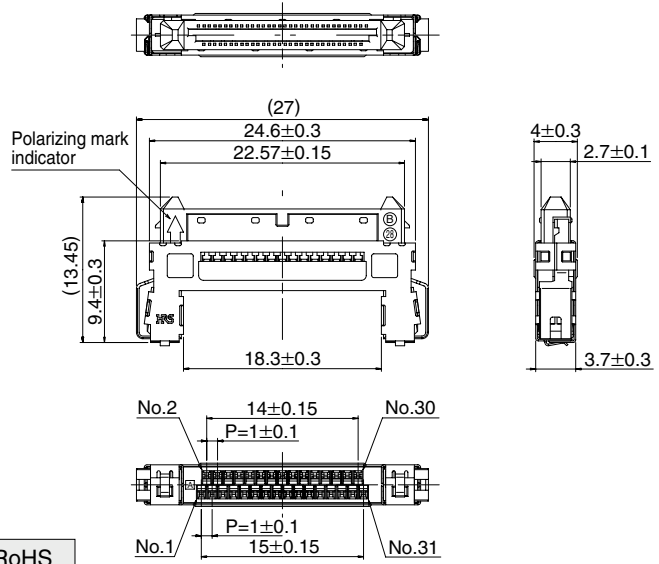

Part number	CL No.	Number of contacts	RoHS
FX15SW-31P-C	CL575-2113-1	31	YES

Note 1: Packaged in trays.

Note 2: Dimensions in parenthesis ( ) are reference dimensions.

●Without shields (FX15M-\*\*P-C)

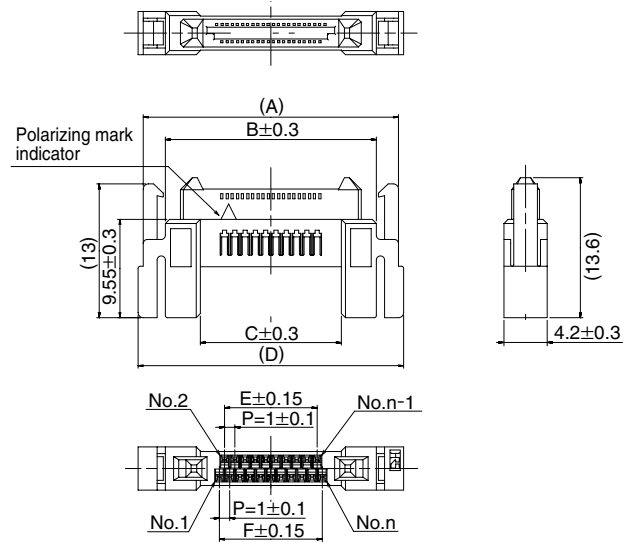
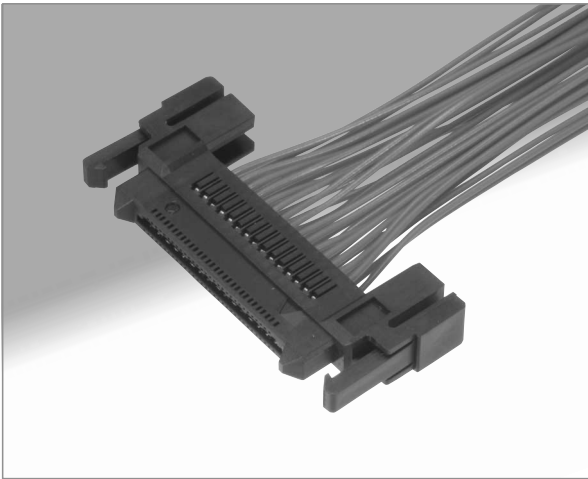

Part number	CL No.	Number of contacts	A	B	C	D	E	F	G	RoHS
FX15M-21P-C	CL575-2109-4	21	24.8	20.5	17.6	13.7	25.8	9	10	YES
FX15M-31P-C	CL575-2108-1	31	29.8	25.5	22.6	18.7	30.8	14	15	

Note 1: Sold in package containing 100 pieces. Order by package.

Note 2: Dimensions in parenthesis ( ) are reference dimensions.

FX15 Series • 1mm Pitch Cable-to-Board Connectors Supporting LVDS signal

## ■ Plug crimp contacts

Part number	CL No.	Packaging	Quantity	Finish	RoHS
FX15-2830PCFB	CL575-2002-0	Reel	20,000 pieces per reel	Gold plated	YES
FX15-3032PCFB	CL575-2003-3				

### ● Applicable cable (Tin plated solid soft strands)

#### FX15-2830PCFB

Applicable wire size (Stranded wire conductor)	Jacket diameter	UL No.
AWG #28 (7/0.127 mm)	φ0.56 to 0.72mm	1517
AWG #30 (7/0.1 mm)		1571

#### FX15-3032PCFB

Applicable wire size (Stranded wire conductor)	Jacket diameter	UL No.
AWG #30 (7/0.1 mm)	φ0.5 to 0.6mm	1516, 1571 (Note)
AWG #32 (7/0.08 mm)		1571

### ● Wire strip length: 1.1 to 1.8 mm

Note: When using other than the recommended wire, contact your nearest Hirose representative.

### ● Tools

Item	Product number	CL No.	Applicable crimp contact
Applicator	AP105-FX15-2830	901-4036-0	FX15-2830PCFB
	AP105-FX15-3032	901-4033-1	FX15-3032PCFB
Press unit	CM-105	901-0005-4	—

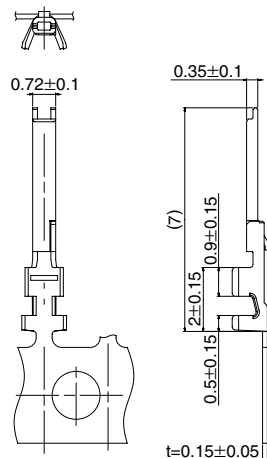

**FX15 Series 1mm Pitch Cable-to-Board Connectors supporting LVDS signal**

**●Plug – Micro-coaxial cable (FX15SC-\*\*P-0.5SD)**

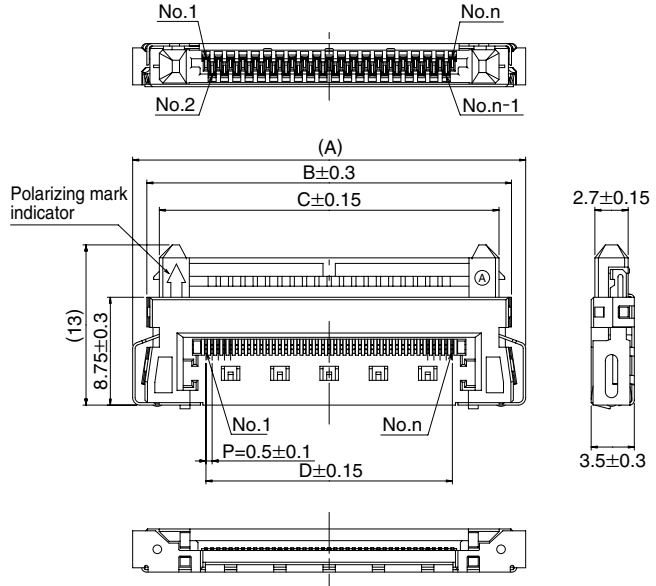
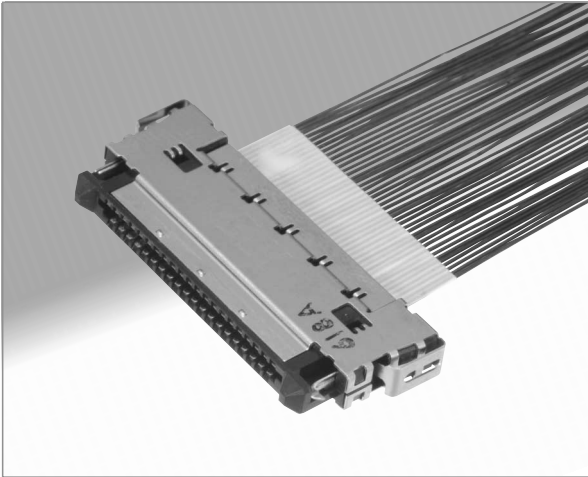

Part number	CL No.	Number of contacts	A	B	C	D	RoHS
FX15S-41P-0.5SD	CL575-2110-3	41	31.9	29.6	27.57	20	YES
FX15S-51P-0.5SD	CL575-2118-5	51	36.9	34.6	32.57	25	

Note 1: Packaged in trays.

Note 2: Dimensions in parenthesis ( ) are reference dimensions.

**●Ground plate for micro-coaxial cable**

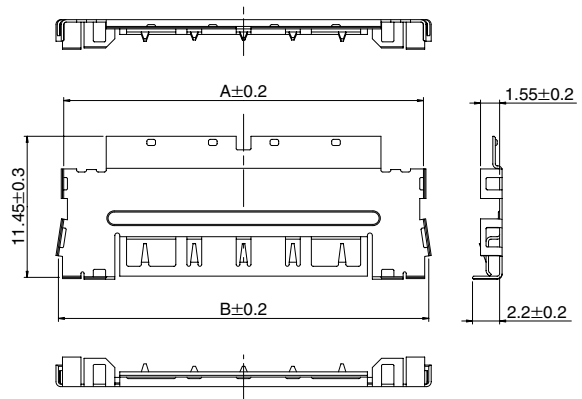
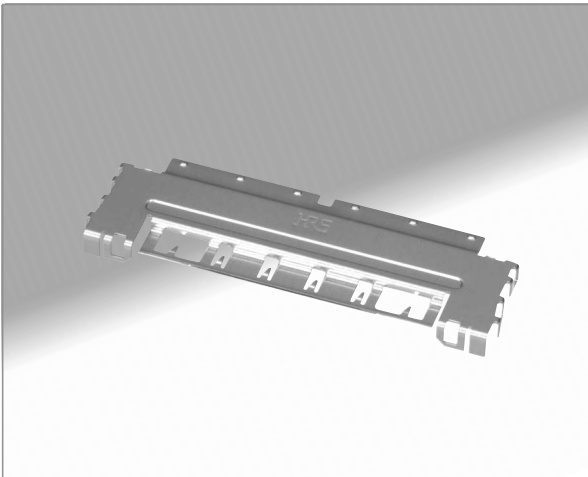

Part number	CL No.	Number of contacts	A	B	RoHS
FX15S-41P-GND	CL575-2111-6	41	29.2	30.06	YES
FX15S-51P-GND	CL575-2117-2	51	34.2	35.06	

Note 1: Packaged in trays.

Note 2: Dimensions in parenthesis ( ) are reference dimensions.



**FX15 Series 1mm Pitch Cable-to-Board Connectors Supporting LVDS signal**

**●Applicable cable (Micro-coaxial cable)**

Wire size (Standed wire inner conductor)	Jacket diameter
AWG #36 (7/0.05 mm)	0.3mm to 0.5mm
AWG #38 (7/0.04 mm)	
AWG #40 (7/0.03 mm)	

Number of contacts	A	B
41	23.1	20
51	28.1	25

**●Cable preparation**

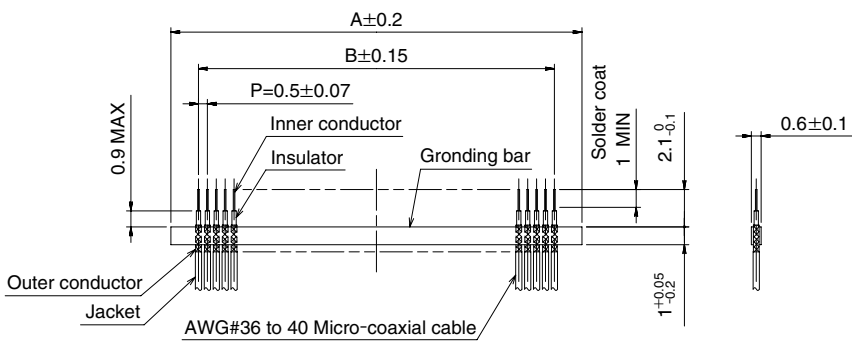



## ■ Receptacles

### ● Vertical, with shields (FX15-31S-0.5SV)

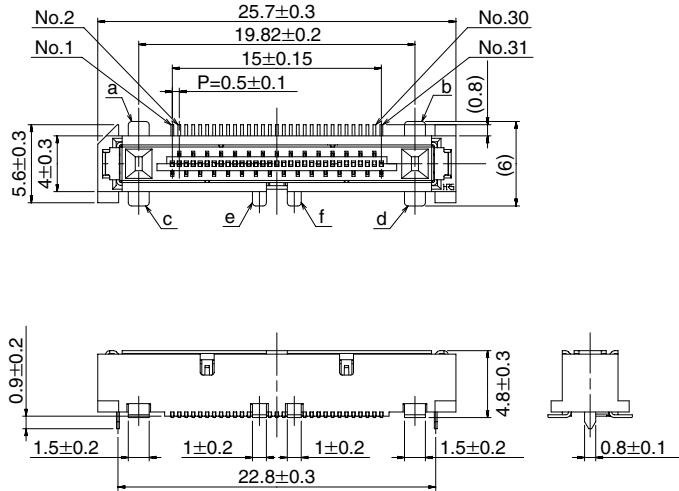
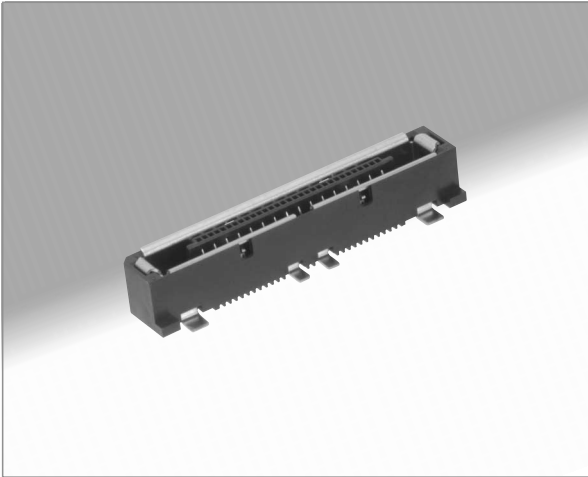

Part number	CL No.	Number of contacts	RoHS
FX15-31S-0.5SV	CL575-2201-7	31	YES

## ◆ Recommended PCB mounting pattern and metal mask dimensions

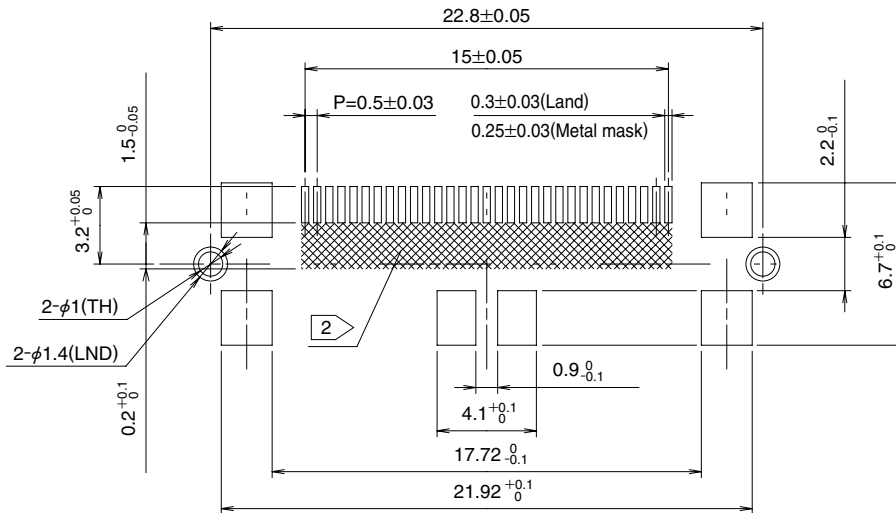

Note 1 :The co-planarity of the terminal leads is as follows:

- All signals and shield leads "c" and "d": 0.1mm max.
- Shield leads "a", "b", "e" and "f": 0.15 mm max.

② : Area indicated by the crosshatched lines must be free of conductive traces or the conductive traces must be covered by resist film.

3 : Packaged on tape-and-reel, 1000 pieces per reel.

4 : Dimensions in parenthesis ( ) are reference dimensions.

**FX15 Series 1mm Pitch Cable-to-Board Connectors Supporting LVDS signal**

**●Right angle with shields – enhanced shielding (FX15S-\*\*\*S-0.5SH)**

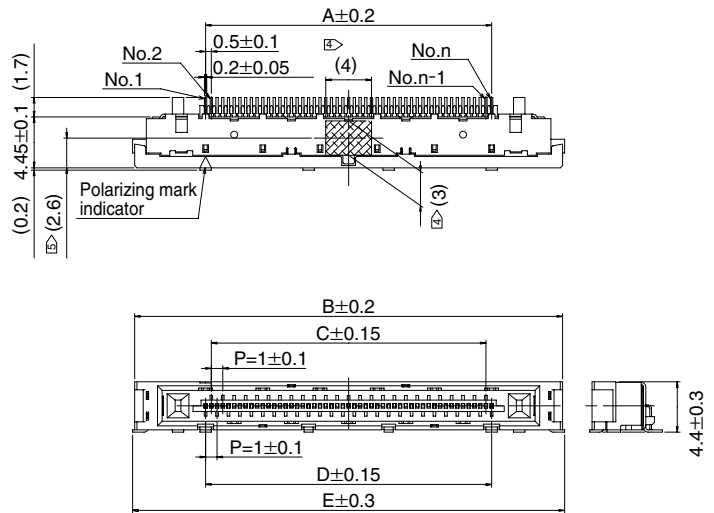
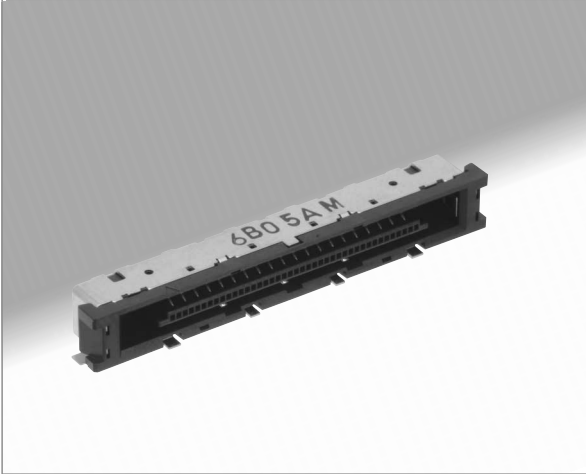

Part number	HRS No.	Number of contacts	A	B	C	D	E	F	G	H
FX15S-31S-0.5SH	CL575-2306-5	31	15	27.4	14	15	27.8	28.8	24.8	21.6
FX15S-41S-0.5SH	CL575-2307-8	41	20	32.4	19	20	32.8	33.8	29.8	26.6
FX15S-51S-0.5SH	CL575-2303-7	51	25	37.4	24	25	37.8	38.8	34.8	31.6

J	K	L	M	N	P	R	S	RoHS
18	15	—	—	13.2	16.8	24.8	40	YES
23	20	5.2	8.8	18.2	21.8	29.8	45	
28	25	5.2	8.8	23.2	26.8	34.8	50	

**◆Recommended PCB mounting pattern and metal mask dimensions**

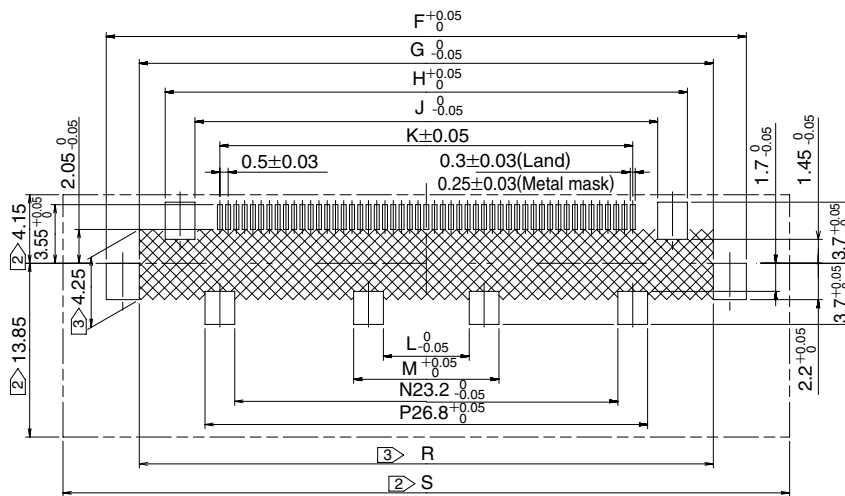

Note 1 : The coplanarity of the terminal leads is 0.1 mm max. for all signal leads and 0.15 mm max. for the shield leads.

- ②: Do not place any components in the area indicated. Placement of components in this area may affect mating and latch lock operation.
- ③: Area indicated by the cross-hatched lines must be free of conductive traces or the conductive traces must be covered by resist film.
- ④: The area marked indicates vacuum pick-and-place area for board placement with automatic equipment.
- ⑤: Vacuum pick-up area
- 6 : Packaged on tape-and-reel, 1000 pieces per reel.
- 7 : Dimensions in parenthesis ( ) are reference dimensions.

●Right angle, without shields (FX15M-\*\*-\*\*S-0.5SH)

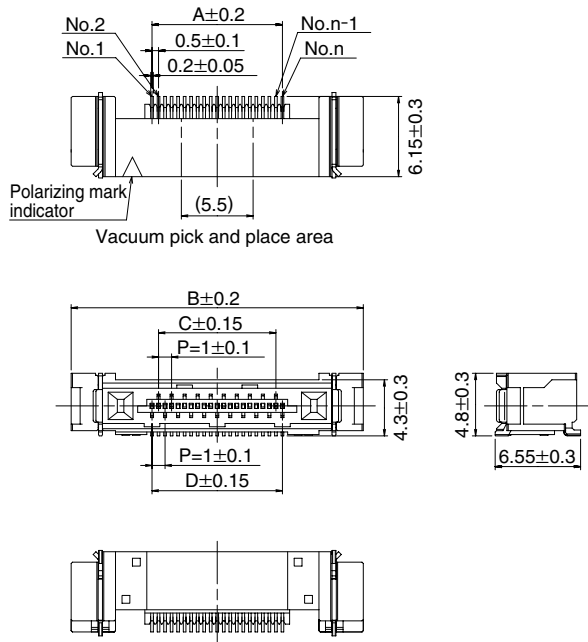
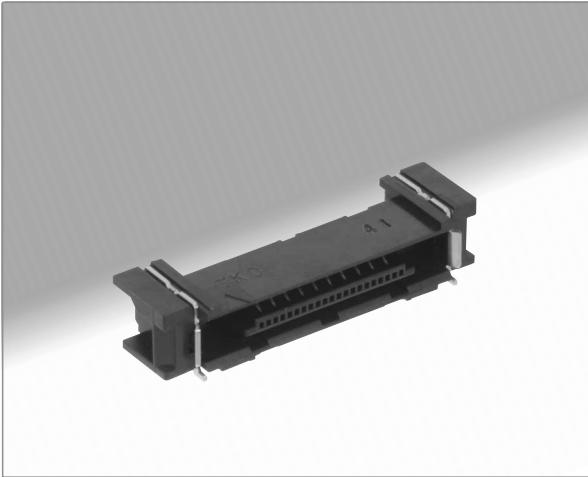

Part number	HRS No.	Number of contacts	A	B	C	D	E	F	G	RoHS
FX15M-21S-0.5SH	CL575-2309-3	21	10	22.4	9	10	17.9	10	35	YES
FX15M-31S-0.5SH	CL575-2308-0	31	15	27.4	14	15	22.9	15	40	

◆Recommended PCB mounting pattern and metal mask dimensions

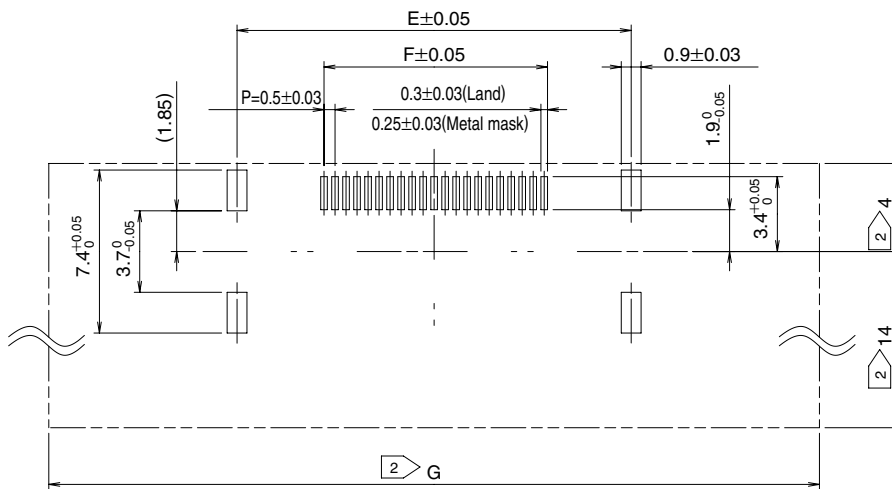

Note 1 : The co-planarity of all terminal leads is 0.1 mm max.

2 : Do not place any components in the area indicated. Placement of components in this area may affect mating and latch lock operation.

3 : Packaged on tape-and-reel, 1000 pieces per reel.

**FX15 Series 1mm Pitch Cable-to-Board Connectors Supporting LVDS signal**

● **Right angle with shields – enhanced shielding (FX15SC-\*\*\*S-0.5SH)**

PCB mounting pattern : VESA standard

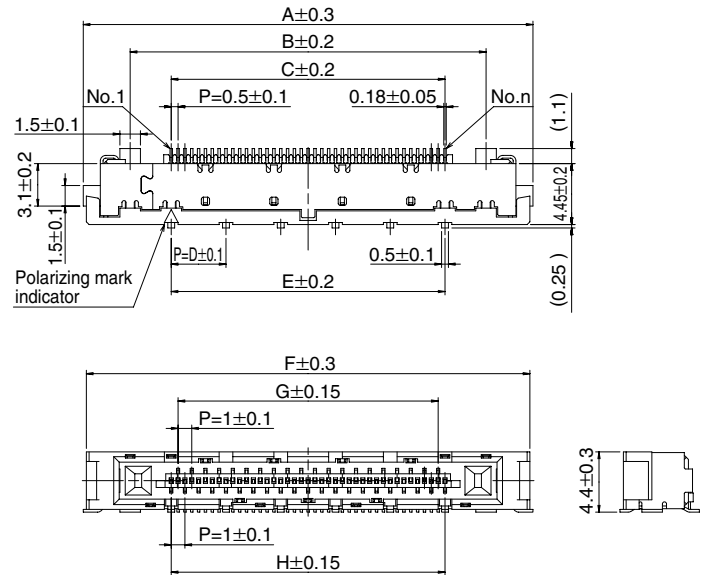
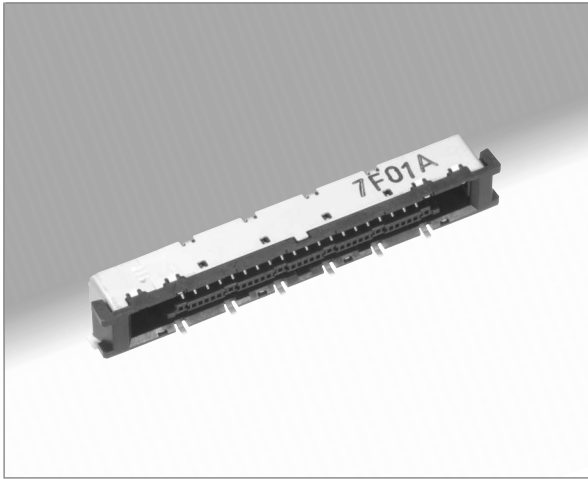

Part number	HRS No.	Number of contacts	A	B	C	D	E	F	G	H	J	K	RoHS
FX15SC-41S-0.5SH	CL575-2310-2	41	32.85	26	20	4	20	32.4	19	20	29.75	45	YES
FX15SC-51S-0.5SH	CL575-2311-5	51	37.85	31	25	5	25	37.4	24	25	34.75	50	

◆ **Recommended PCB mounting pattern and metal mask dimensions**

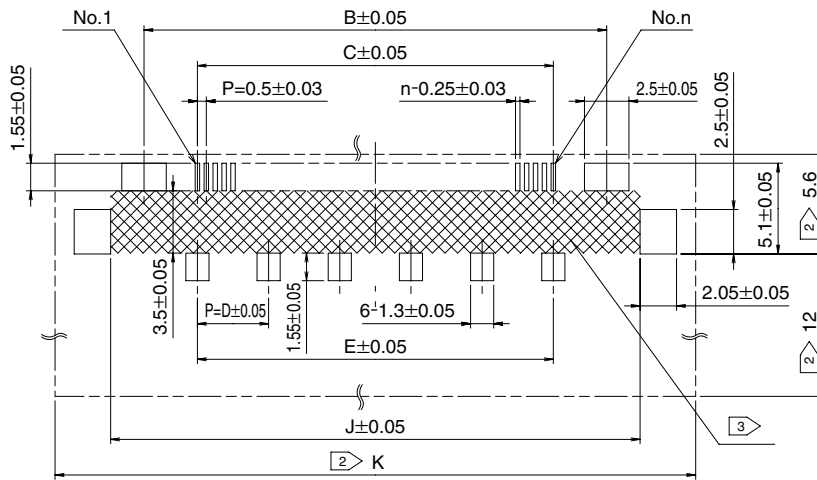

Note 1 : The coplanarity of the terminal leads is 0.1 mm max.

- ② : Do not place any components in the area indicated. Placement of components in this area may affect mating and latch lock operation.
- ③ : Area indicated by the cross-hatched lines must be free of conductive traces or the conductive traces must be covered by resist film.
- 4 : Packaged on tape-and-reel, 1000 pieces per reel.
- 5 : Dimensions in parenthesis ( ) are reference dimensions.

●Vertical with shields – enhanced shielding (FX15SC-\*\*S-0.5SV)  
 PCB mounting pattern : VESA standard

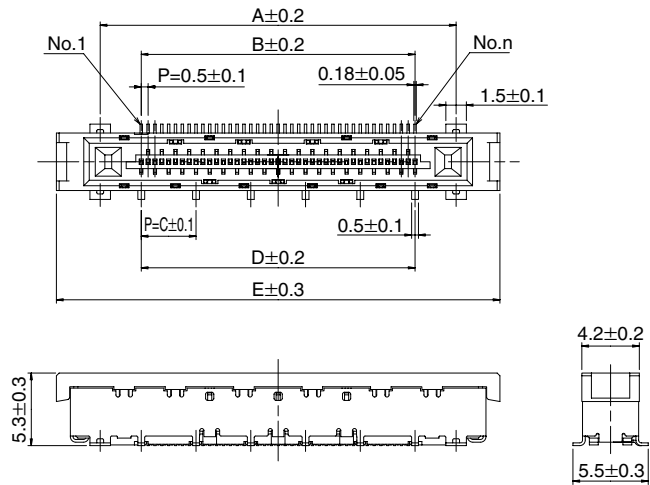
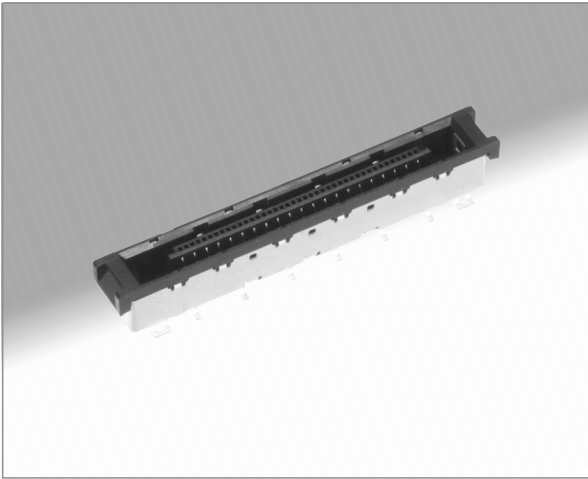

Part number	CL No.	Number of contacts	A	B	C	D	E	RoHS
FX15SC-41S-0.5SV	CL575-2205-8	41	26	20	4	20	32.4	YES
FX15SC-51S-0.5SV	CL575-2204-5	51	31	25	5	25	37.4	

◆Recommended PCB mounting pattern and metal mask dimensions

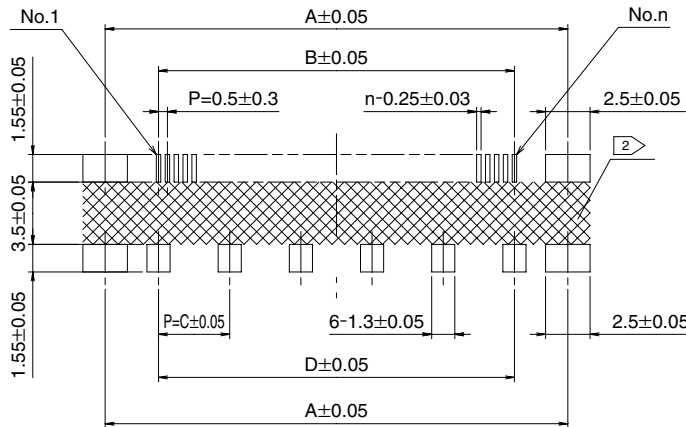

Note 1 : The coplanarity of the terminal leads is 0.1 mm max.

②: Area indicated by the cross-hatched lines must be free of conductive traces or the conductive traces must be covered by resist film.

3 : Packaged on tape-and-reel, 1000 pieces per reel.

FX15 Series • 1mm Pitch Cable-to-Board Connectors Supporting LVDS signal

## ■ Packaging Specifications

### ● Vertical, with shields (FX15-31SC-0.5SV)

Part number	HRS No.	Number of contacts	D
FX15-31S-0.5SV	CL575-2201-7	31	44.5

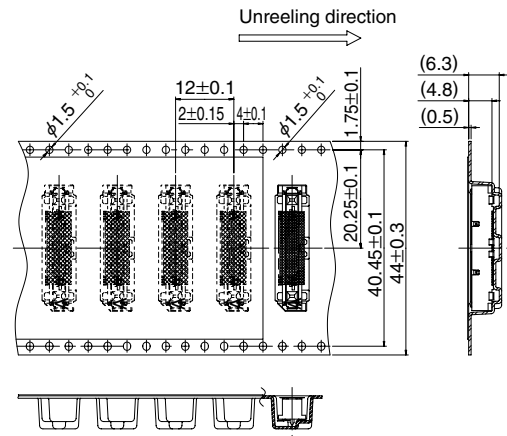

### ● Right angle, with shields-enhanced shielding (FX15S-\*\*\*S-0.5SH)

Part number	HRS No.	Number of contacts	A	B	C	D
FX15S-31S-0.5SH	CL575-2306-5	31	20.3	40.5	44	44.5
FX15S-41S-0.5SH	CL575-2307-8	41	26.3	52.5	56	56.5
FX15S-51S-0.5SH	CL575-2303-7	51	26.3	52.5	56	56.5

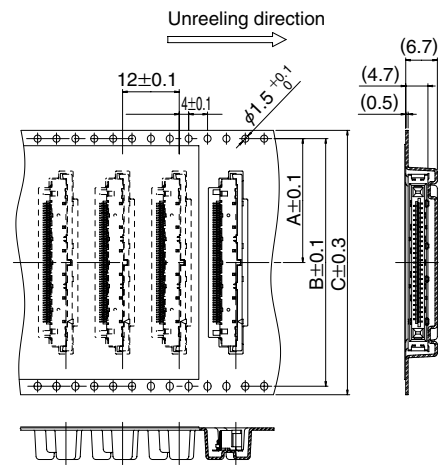

### ● Right angle, without shields (FX15M-\*\*\*S-0.5SH)

Part number	HRS No.	Number of contacts	A	B	C	D
FX15M-21S-0.5SH	CL575-2309-3	21	20.2	40.4	44	44.5
FX15M-31S-0.5SH	CL575-2308-0	31	20.2	40.4	44	44.5

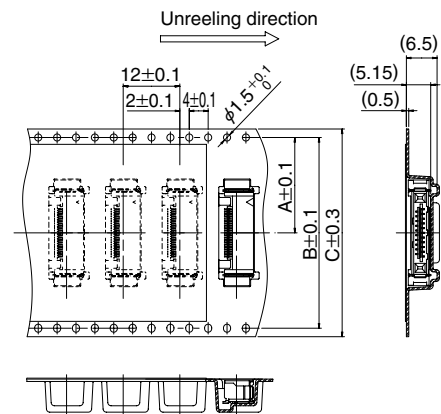

### ● Reel dimensions

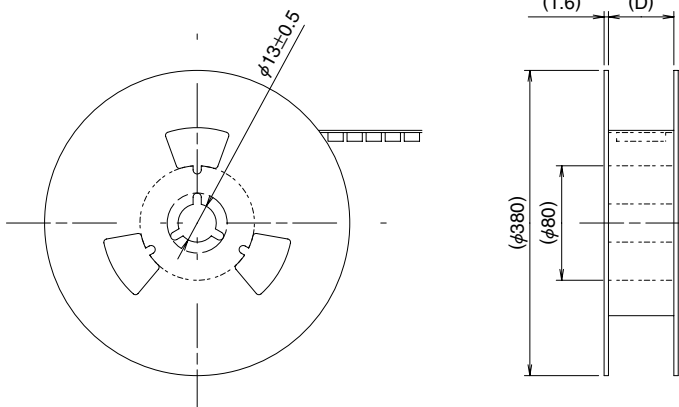

●Right angle with shields – enhanced shielding  
 (FX15SC-\*\*\*S-0.5SH)

Part number	HRS No.	Number of contacts	A	B	C	D	RoHS
FX15SC-41S-0.5SH	CL575-2310-2	41	26.2	52.4	56	56.5	YES
FX15SC-51S-0.5SH	CL575-2311-5	51	26.2	52.4	56	56.5	

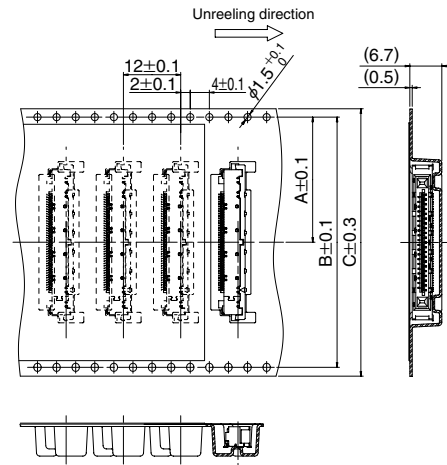

●Vertical with shields – enhanced shielding  
 (FX15SC-\*\*\*S-0.5SV)

Part number	HRS No.	Number of contacts	A	B	C	D	RoHS
FX15SC-41S-0.5SV	CL575-2205-8	41	26.2	52.4	56	56.5	YES
FX15SC-51S-0.5SV	CL575-2204-5	51	26.2	52.4	56	56.5	

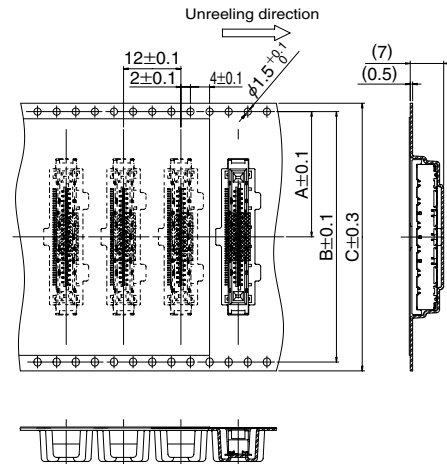

●Reel dimensions

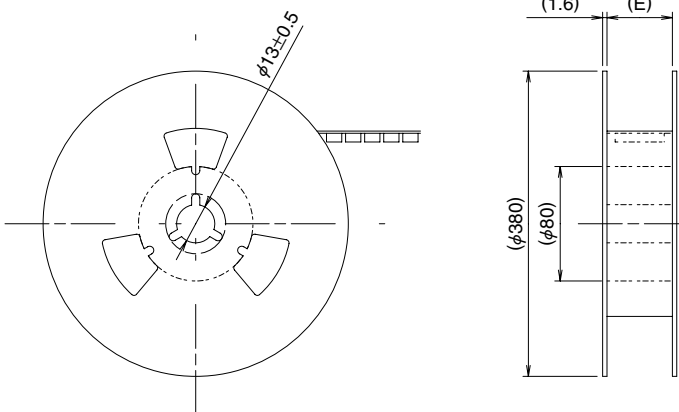



**FX15 Series 1mm Pitch Cable-to-Board Connectors Supporting LVDS signal**

**◆ Recommended temperature profile**

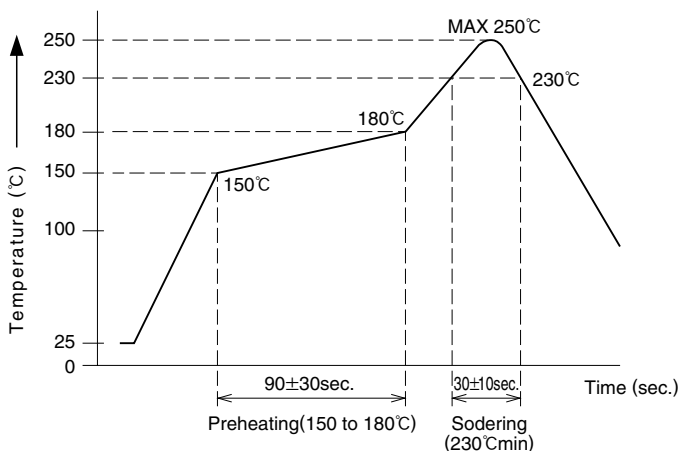

**HRS test conditions**

Test board Glass epoxy 40mm×30mm×1mm thick  
 Solder method :Reflow  
 Solder composition :Paste,  
 96.5%Sn/3%Ag/0.5%Cu  
 Metal mask : 0.12mm thick  
 Reflow cycles : 2 cycles

The temperature profile is based on the above conditions.  
 In individual applications the actual temperature may vary, depending on solder paste type, volume/thickness and board size/thickness. Consult your solder paste and equipment manufacturer for specific recommendations.

Note: The temperature profile indicates the maximum temperature of the connector surfaces at the highest point from the PCB mounting surface.

**◆ Cleaning recommendations**

**Organic solvent cleaning**

Solvent type	Room temperature cleaning	Heated cleaning
IPA (Isopropyl alcohol)	YES	YES
HCFC (Hydrochlorofluorocarbon)	YES	YES

**Water based cleaning**

When using water based cleaning agents (e.g., terpene, alkali saponifiers), select the cleaning agent based on the documentation issued by the various manufacturers of cleaning agents which describes it's affects on metals, platings and plastics. Remove any moisture after cleaning. Residual flux or cleaning agents in the contact areas may affect electrical performance.

## Precautions and recommendations

### ◆Wire termination

The following documents will be needed in order to perform the cable terminations.

- ① Basic cable termination and crimp requirements (general explanations)
- ② Contact crimp termination machine instruction manual (Explanation of the press)
- ③ Applicator parts installation table (Applicator installation explanation)
- ④ Crimp conditions table (Crimp height/Tensile strength standard values)
- ⑤ Crimp quality fundamentals manual (Bell-mouth dimensions, bent up, bent down, rolling, etc.)

\* Correct cable preparation and crimp termination is based on understanding and following the procedures in the above documents.

### ◆Insertion of the crimp contacts in the housing

Crimp contacts are inserted in the housing as illustrated below.

Exercising caution when inserting, align the retention tab of the contact with the corresponding molded-in lance in the housing's contact cavity and push the contacts in.

Make sure that the contact is fully inserted and the retention tab clears the molded-in lance.

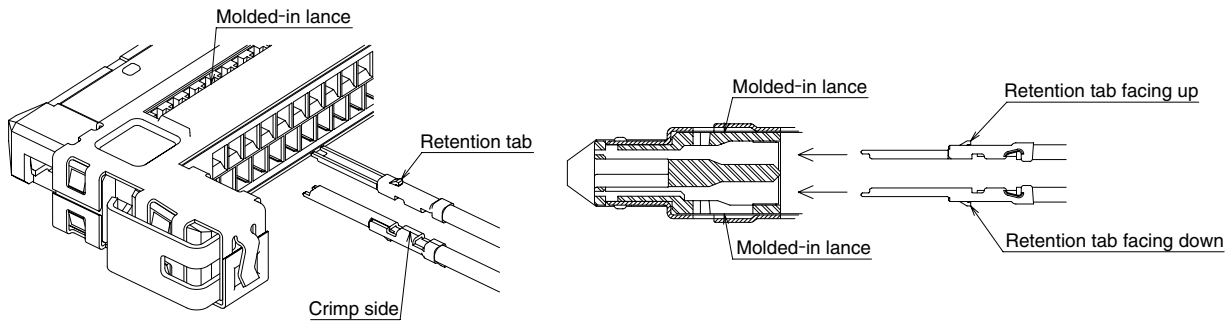

### ◆Verify that the retention tabs clear the molded-in lances as shown on the illustration below.

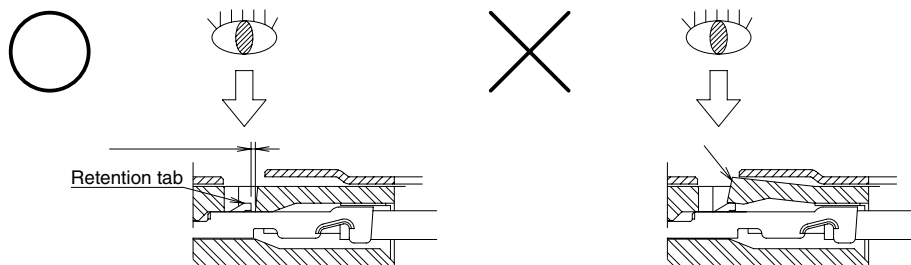

Light pull on the wire, with force NOT EXCEEDING 3N will also verify the correct contact insertion.

### ◆Removal of the contacts

Using sharp-pointed tool of appropriate size gently lift the molded-in tab and pull-out the terminated contacts.

Excercise caution as NOT to damage the molded-in lance.

Should the damage occur, the entire housing will need to be replaced.

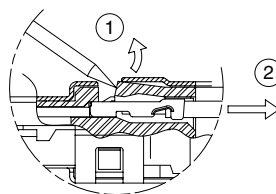

## Precautions and recommendations

[ Soldering precautions related to FX15S-\*\*P-C connectors ]

◆Grounding Methods of the ground wire or shields for the cable assemblies

- ① Solder the ground wire or the shields ONLY in the areas specifically designated for this purpose, as shown on the illustrations below.
- ② Observe the soldering iron tip temperature and soldering time specified.
- ③ Do not apply excessive force to the connector by pressing it with the tip of a soldering iron.
- ④ Do not splatter the flux from the solder core.

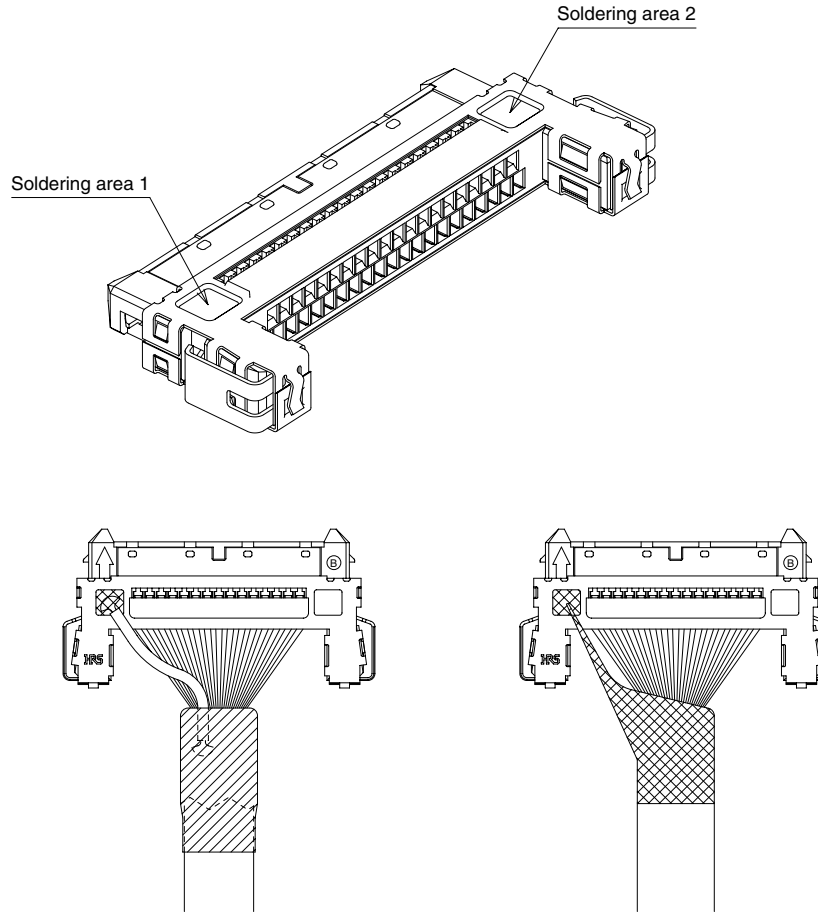

(Ground harness examples)

## Precautions and recommendations

### ◆Plug – micro-coaxial cable

#### [ Cautions for soldering ]

1. For the micro coaxial cable assembled to this connector, cable alignment process as shown in "Recommended cable" on the page 1 is required before assembly.

①Width of ground bar shall be 1.05 mm Max. including misalignment of overlapping, flush by cutting, side drop or soldering.  
 Using an inadequate cable will interfere the assembly to the connector. Forceful assembly and soldering could cause mis-soldering to defective product.

②Minimize the length of outer conductor beyond the ground the bar.

③Length of cutting the extra cable shall be 2.1 mm Max.  
 Its over length will cause the cable touching the connector body during assembly and cause defective product.  
 Minimal length 2.0 mm is a recommended dimension and allowed to be changed if necessary, as long as ensuring good solderability.

④Pre-solder and coat the inner conductor at the cable end.

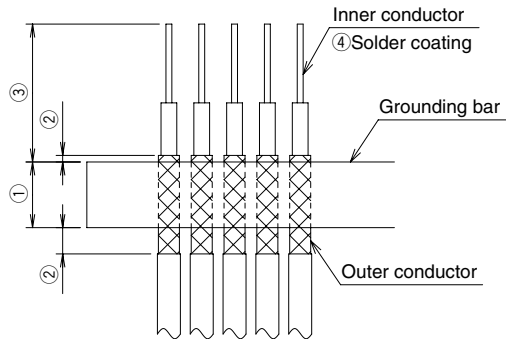

2. Recommended solder for the assembly is flux cored solder with 0.2 mm dia. (Lead-free: Sn-3Ag-0.5Cu), 21 mm length.  
 If you consider using additional flux, please pay enough attention not to have flux wicking to the contact area.  
 Flux wicking to the contact area will cause contact failure.

3. Place the cable to the connector and check the below points before soldering by cable assembly machine.

- ①Misalinment of cable end to the terminals in pitch direction
- ②Excessive floating of cable end

4. Follow the recommended temperature profile shown below for the soldering.

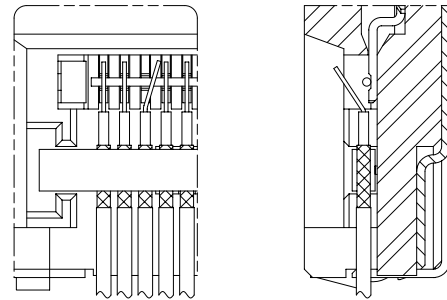

①Misalignment in pitch direction      ②floating

However, the optimum condition could vary depending on various including type of cable and its length, solder type. Therefore refer to the recommended temperature profile and optimize the condition if necessary.

Solder tip pressurization	13~17N
---------------------------	--------

#### Heating

Temperature	265±5°C
Duration	3~4 sec

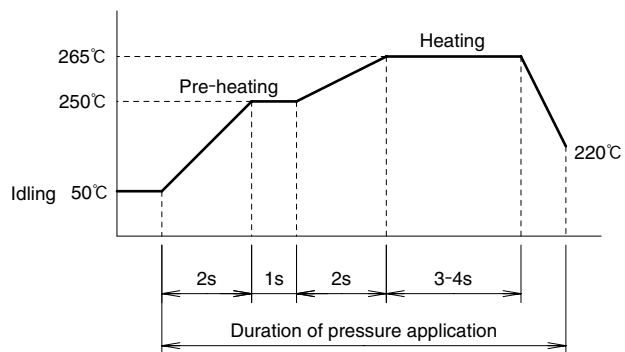

FX15 Series 1mm Pitch Cable-to-Board Connectors Supporting LVDS signal

**Precautions and recommendations**

5. After soldering, check that no defect is found at soldered area.  
 Examples of correct soldered and defective soldered state are shown below.

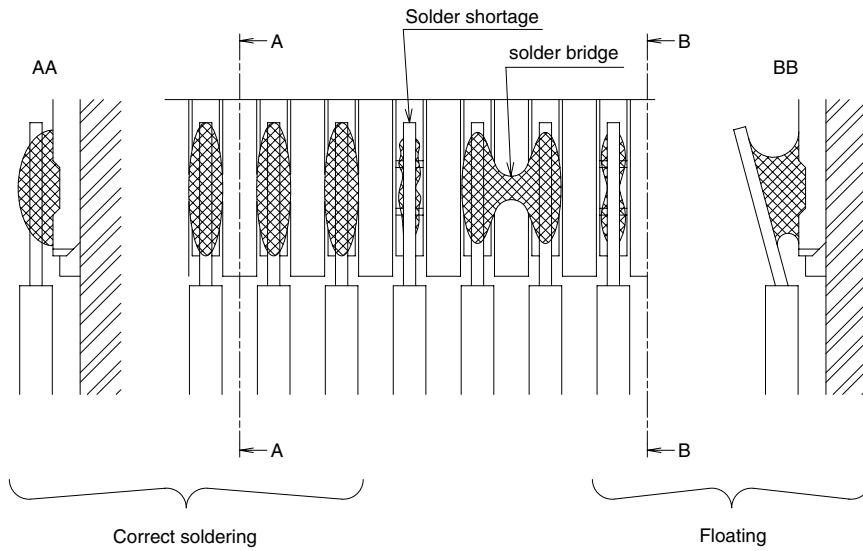

[ Cautions for potting process ]

1. Protect the soldered area by UV cured resin (referred as "potting" hereafter), in order to prevent cable breakage during cabling and other troubles.
2. Apply 3033 manufactured by THREEBOND CO., LTD. or any equivalent product for potting.  
 Follow the instruction of potting manufacture's for the condition of UV exposure.
3. Refer to the following conditions the potting area.

Number of contacts	A
41	23.7
51	28.7

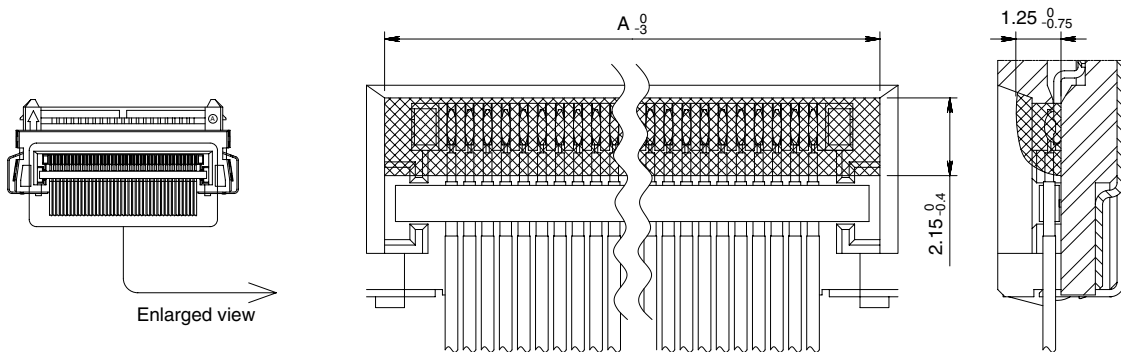

4. Use extreme care for the handling after soldering to the end potting process not to apply stress to the cable, otherwise, cable could be broken.

## Precautions and recommendations

[ Cautions for ground plate assembly ]

1. Attach a ground plate separately provided as FX15S-41P-GND after the cable assembly process.
2. Place the ground plate onto the connector horizontally and pinch two components from top and bottom with fingers.

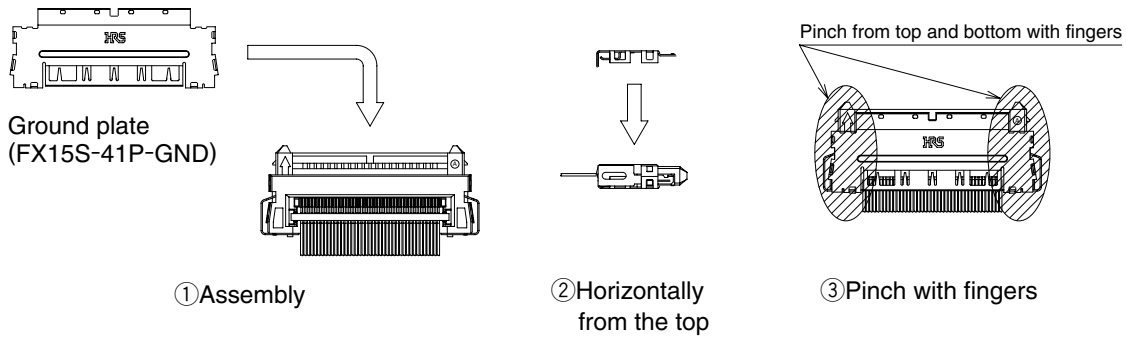

3. Check the six fitting points after assembly and make sure that they are all correctly fitted together.

### How to check fitting points

(Cut section of fitting points)

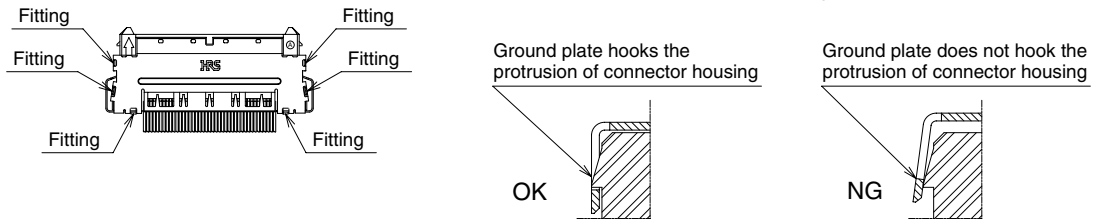

[ Soldering to ground plate ]

1. Solder down the metal bar of the cable and ground plate after the assembly of ground plate in order to enhance the grounding performance and robustness against cable stroke to up and down direction.

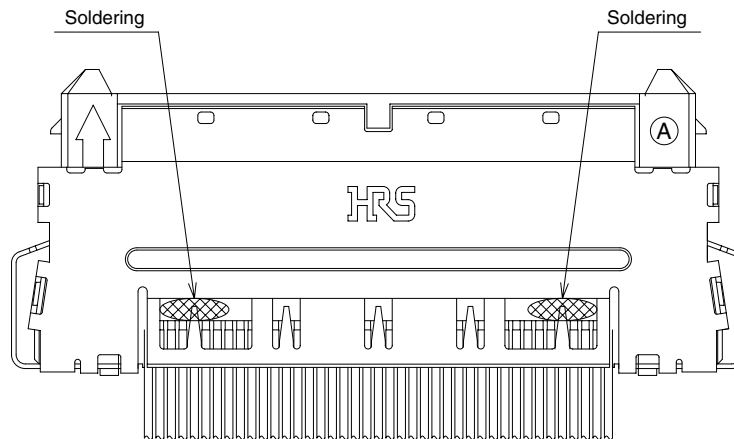

## Precautions and recommendations

### ◆Packaging of the complete cable assemblies

Exercise caution as not to tangle, twist or deform the complete cable assemblies when packaging. Special care should be taken NOT to apply any excessive pull forces to the individual wires.

When removing the cable assemblies from the packaging do not pull on the wires. Make sure that the latch-locks are not interfering with packaging.

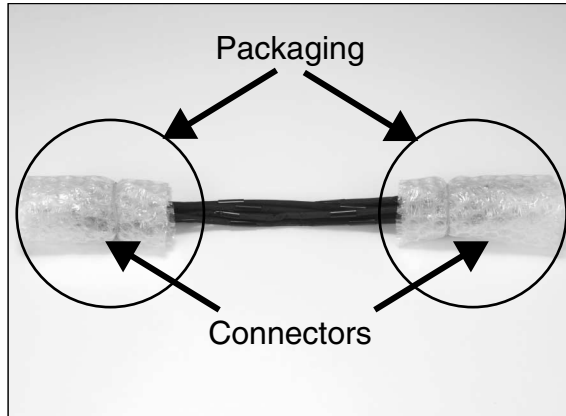
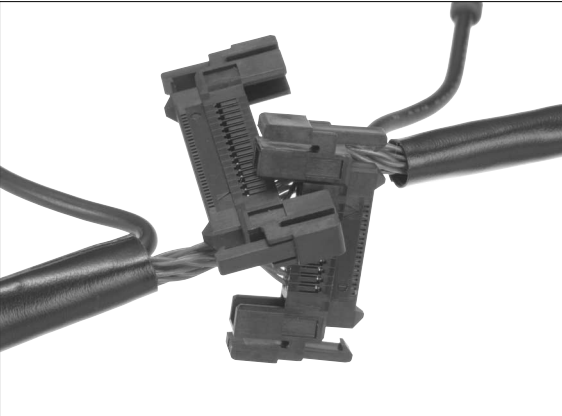

### ◆Mating of the connectors

The connectors have built-in polarizing feature and will NOT mate when reversed. Do NOT try forced mating.

Align the connectors as shown on the illustration below and fully insert the plug into the receptacle. Confirm that both latch-locks are fully engaged.

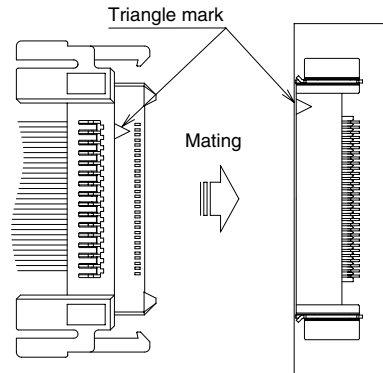
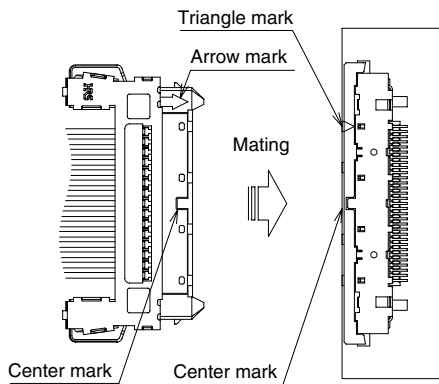



## Precautions and recommendations

### ◆ Handling of Connectors after Mating

Do not apply excessive forces to the connectors when routing the cable after mating.

Pulling on the entire cable with a force of 20 N or greater can damage the connector. Please take due care not to pull the cable.

### ◆ Un-mating of the connectors

Depress equally both sides of the latch-locks as shown on the illustration and pull the plug straight out. Do not pull on the cables!

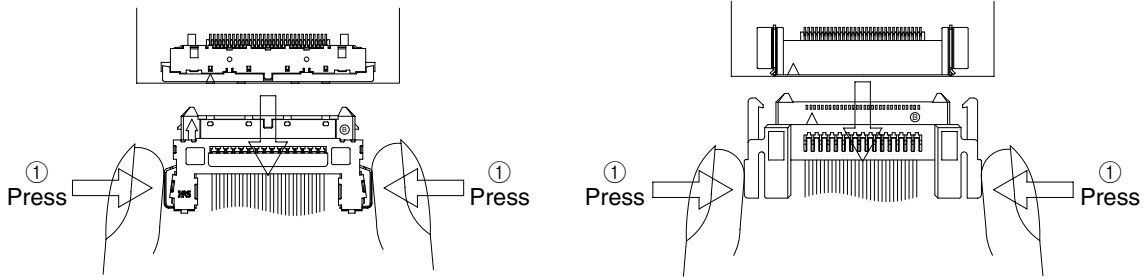

② Pull straight apart

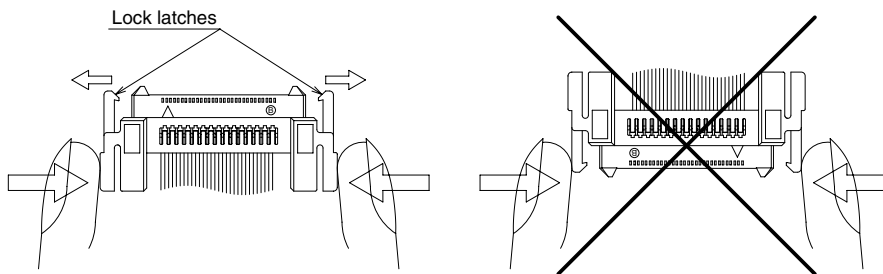
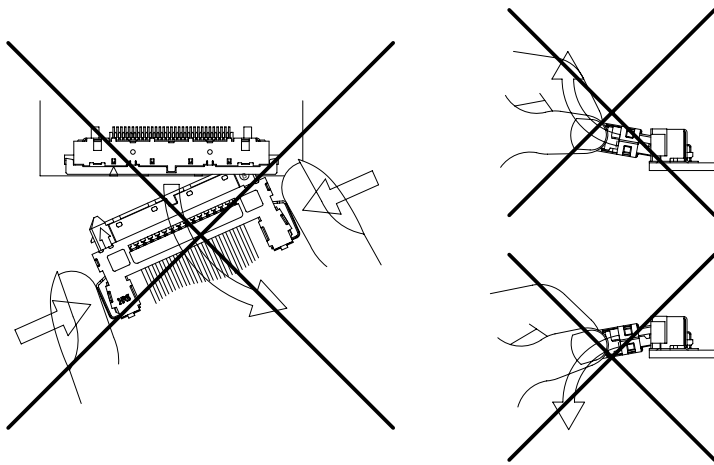

## ◆ Technical Information (FX15S Series)

### ● Eye Pattern Waveforms (700 MHz)

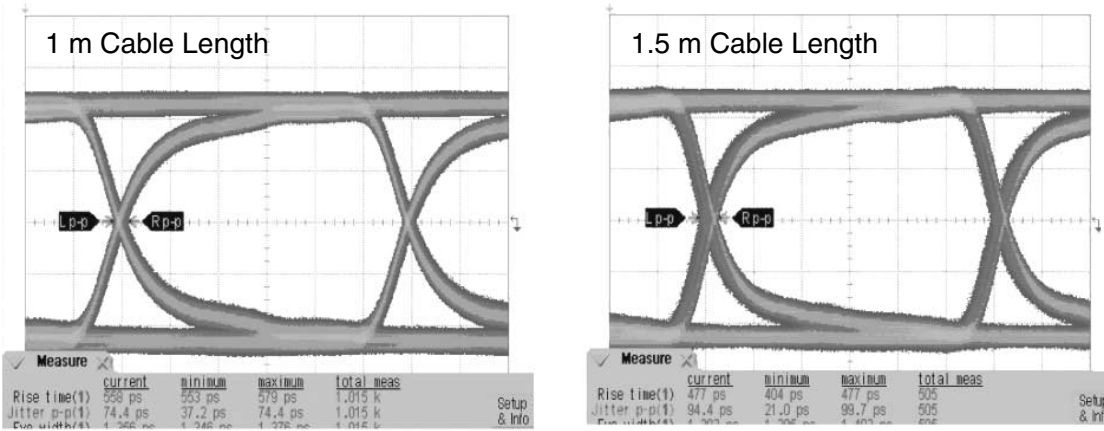

### ● Shielding Effectiveness (Shielding Characteristics Comparison Using a 2-chamber Shielded Room)

Measured shielding effectiveness for frequencies from 100 MHz to 2 GHz.

Shielded connectors show noise suppression of 10 dB to 20 dB, when compared with connectors without the shields.

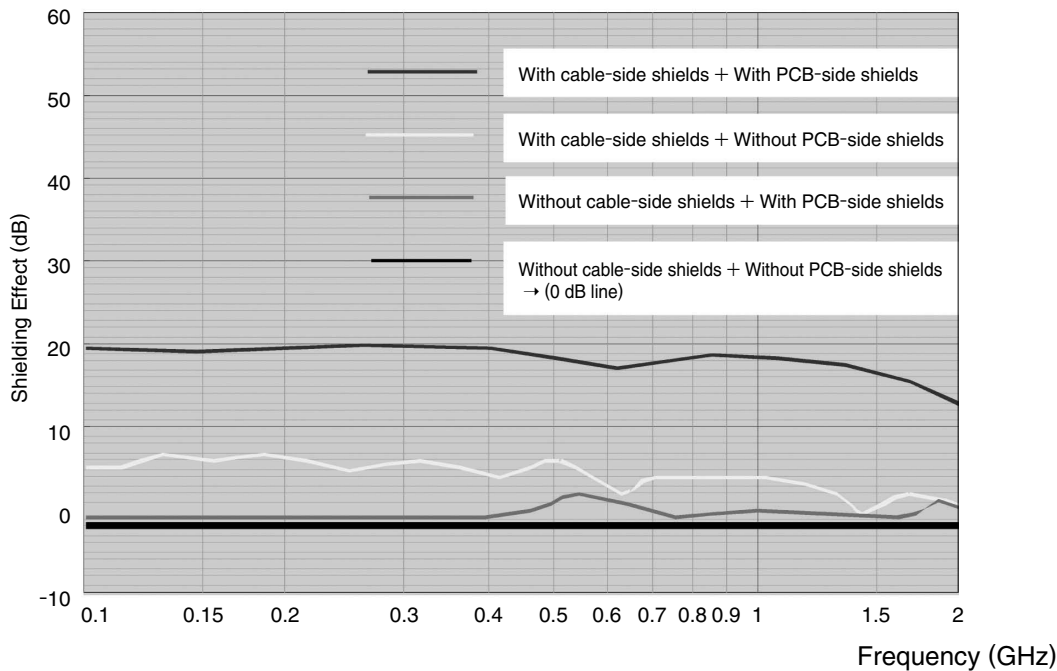

Notes: The measurement value of "Without plug-side shields + Without receptacle-side shields" are taken as the zero level of the graph vertical axis dB.

The respective results express the noise suppression effect (dB) as a relative comparison value with this "without shields" condition as the reference.