

PROPER USE GUIDELINES

Cumulative Trauma Disorder can result from the prolonged use of manually powered hand tools. NorComp hand tools are intended for the occasional use and low volume applications. NorComp offers a wide selection of powered application equipment for extended use, production operations.

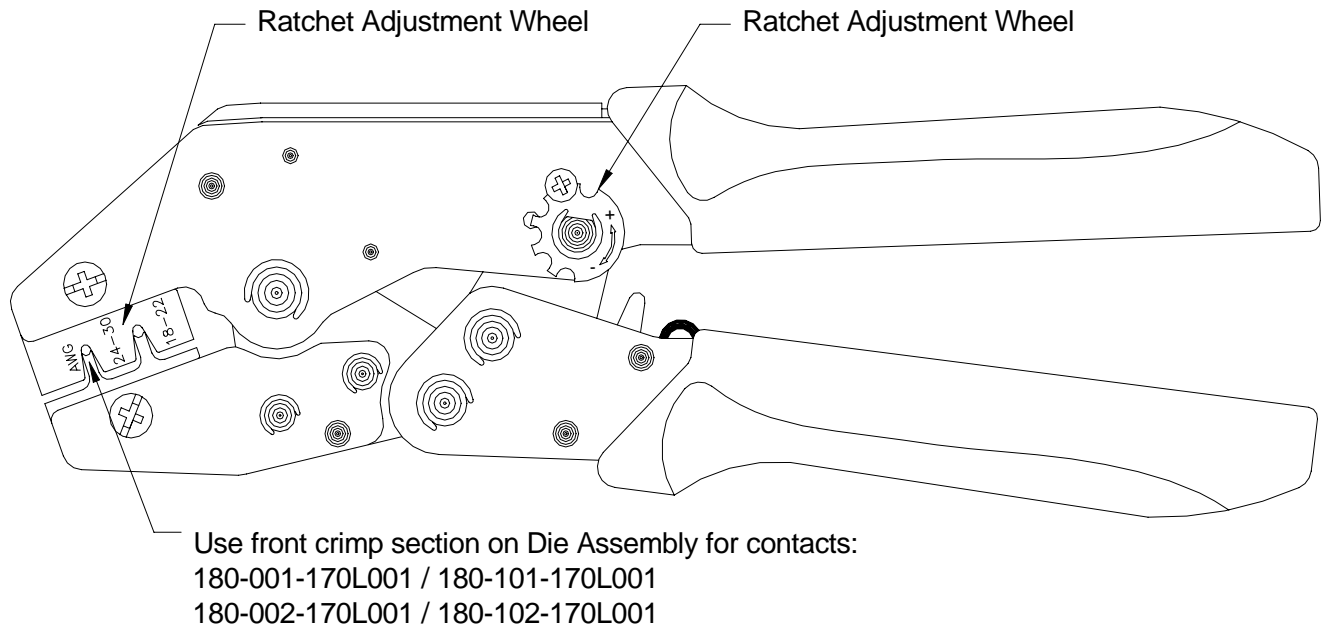

HAND TOOL	CONTACT SIZE RANGE (AWG)	WIRE INSULATION DIAMETER Max in. [mm]	STRIP LENGTH in. [mm]
180-701-170-000	28-24	0.040 [1.02]	0.100 [2.54]

Figure 1

1. INTRODUCTION

NorComp 180-701-170-000 Hand Tool Assembly consists of Die Assembly and Hand Tool Frame.

CAUTION *Read these instructions thoroughly before crimping any contacts.*

2. DESCRIPTION

The tool features a tool frame with a stationary jaw and handle, moving jaw, moving handle, and adjustable ratchet that ensures full contact crimping. The tool frame holds a die assembly with two crimping chambers.

The die assembly features a wire anvil, insulation anvil, wire crimper, and insulation crimper.

NOTE: Use front crimp section only for contacts:
 180-001-170L001 / 180-101-170L001
 180-002-170L001 / 180-102-170L001

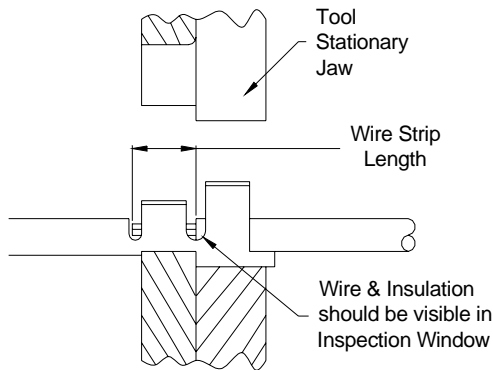

Figure 2

3. CRIMPING PROCEDURE

NOTE *This tool provided with a crimp adjustment feature.*

Refer to Figure 1, and select wire size of the specified size and insulation diameter. Strip the wire to the length indicated, taking care not to nick or cut the wire strands. Select an applicable contact and identify the appropriate crimping chamber according to the wire size markings on the tool.

Refer to Figure 2, and proceed as follows:

1. Hold the tool so that the front is facing you. Squeeze tool handles together and allow them to open fully.
2. Insert the contact (mating end first) into the hole in the locator which corresponds with the appropriate crimping chamber. Make sure that the open "U" of the wire barrel and insulation barrel face the stationary jaw.

CAUTION *Make sure that both sides of the contact insulation barrel are started evenly into the crimping chamber. Do NOT attempt to crimp an improperly positioned contact.*

3. Hold the contact in position, and squeeze the tool handles together until ratchet engages sufficiently to hold the contact in position. Do NOT deform insulation barrel or wire barrel.
4. Insert stripped wire into contact insulation and wire barrels until wire and insulation are visible in inspection window, as shown in Figure 2.
5. Holding the wire in place, squeeze the tool handles together until ratchet releases. Allow tool handles to open and remove crimped contact.
6. Check the contact crimp as described in Section 4, CRIMP HEIGHT INSPECTION. If necessary, adjust the crimp height as described in Section 4, CRIMP HEIGHT ADJUSTMENT.

4. CRIMP HEIGHT INSPECTION

This inspection requires the use of a micrometer with a modified anvil. It is recommended that the modified micrometer (Crimp Height Comparator RS-1019-5LP) be purchased from:

Shearer Industrial Supply Co.
20 North Penn Street
York, PA 17401-1014

OR

VALCO
1410 Stonewood Drive
Bethlehem, PA 1807-3527

Proceed as follows:

1. Refer to Figure 3 and select the *maximum* size wire for the crimping chamber.
2. Refer to Section 3, CRIMPING PROCEDURE, and crimp the contact accordingly.
3. Using a crimp height comparator, measure the wire barrel crimp height as shown in Figure 3. If the crimp height conforms to that shown, the tool is considered dimensionally correct. If not, the tool must be adjusted. Refer to Section 5, CRIMP HEIGHT ADJUSTMENT.

4. Re-assemble the lockscrew.
5. Make a sample crimp and measure the crimp height. If the dimension is unacceptable, continue to adjust the ratchet, and again measure a sample crimp.

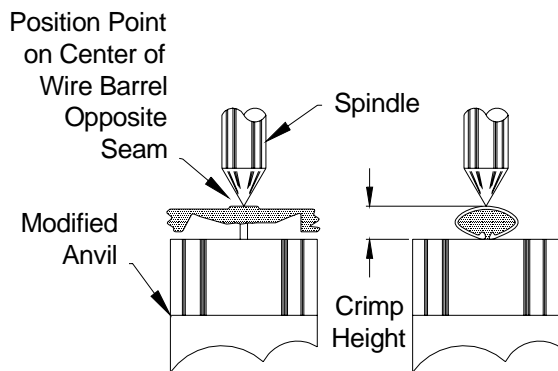

WIRE SIZE Max AWG	CRIMP HEIGHT in.	TEST PULL lb.
28	0.026 ±0.001	4
26	0.027 ±0.001	6
24	0.030 ±0.001	8

Figure 3

5. CRIMP HEIGHT ADJUSTMENT

1. Remove the lockscrew (see Figure 4) from the ratchet adjustment wheel.
2. Use a screwdriver to adjust the ratchet wheel.
3. Observe the ratchet adjustment wheel. If a tighter crimp is required, rotate the adjustment wheel *counterclockwise* toward the "+" setting. If a looser crimp is required, rotate the adjustment wheel *clockwise* toward the "-" setting.

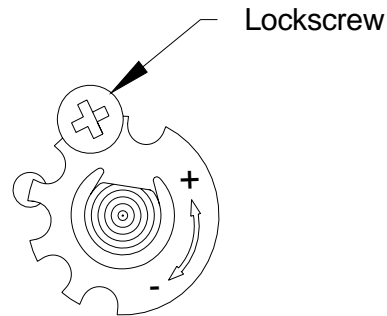

Figure 4

6. MAINTENANCE

Ensure that the tool and dies are clean by wiping them with a clean, soft cloth. Remove any debris with a clean, soft brush. Do not use objects that could damage the tool. When not in use, keep handles closed to prevent objects from becoming lodged in the crimp dies, and store in a clean, dry area.

7. VISUAL INSPECTION

The crimping dies should be inspected on a regular basis to ensure that they have not become worn or damaged. Inspect the crimping chambers for flattened, chipped, worn, or broken areas. If damage or abnormal wear is evident, the tool must be replaced.