

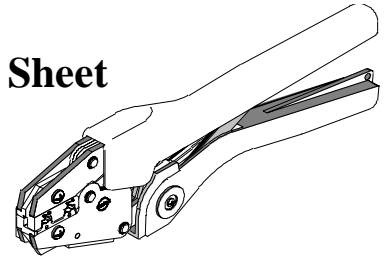

Hand Crimp Tool
Operating Instruction and Specifications Sheet
Part No. 64001-4300
Eng. No. RHT AFIFG
(Replaces 19285-0060)



FEATURES

- A full cycle ratcheting hand tool ensures complete crimps
- Long handles for comfortable crimping with reduced crimping force
- A precision user-friendly terminal locator holds terminals in proper crimping position

SCOPE

AviKrimp® Fully Pre-Insulated and-Insulated Quick Disconnect Flags 14-22 AWG.

Testing

Mechanical

The tensile test, or pull test, is a means of evaluating the mechanical properties of the crimped connections. The following charts show the specifications for various wire sizes. The tensile strength is shown in pounds and indicates the minimum acceptable force to break or separate the terminal from the conductor.

Wire Size (AWG)	*UL - 310
22	8
20	13
18	20
16	30
14	50

*UL – 310 – Quick Disconnects

The following is a partial list of the product part numbers and their specifications that this tool is designed to run. We will be adding to this list and an up to date copy is available on www.molex.com.

Wire Size: 18 – 22 AWG 0.80 – 0.35 mm ²					
Terminal No.	Terminal Eng No. (REF)	Wire Strip Length		Insul. Dia. Max.	
		In.	mm	In.	mm
19006-0001	AA-5220	.344	8.73	.150	3.81
19006-0005	AA-5222	.344	8.73	.150	3.81
19006-0008	AA-5223	.344	8.73	.150	3.81

Wire Size: 14 – 16 AWG 2.00 – 1.30 mm ²					
Terminal No.	Terminal Eng No. (REF)	Wire Strip Length		Insul. Dia. Max.	
		In.	mm	In.	mm
19006-0011	BB-5221	.344	8.73	.170	4.32
19006-0015	BB-5224	.344	8.73	.170	4.32
19006-0017	BB-5225	.344	8.73	.170	4.32

OPERATION

Open the tool by first closing the jaws sufficiently for the ratchet mechanism to release.

Crimping Terminals

1. Insert the terminal with the barrel into the color-coded nest and the square edge of the flag facing out for 14-16 AWG and in for 18-22 AWG. Make sure the back of the flag terminal is against the locator, (See Figure 1). If terminal is not flush against the locator loosen the M4 wing nut and adjust the locator up or down so that the flat edge of the terminal is flush against the wall of the locator. Tighten the M4 wing nut, (See Figure 3).
2. Partially close the tool to hold the terminal in place, (See Figure 2).
3. Insert the properly stripped wire into the terminal barrel, (See Figure 2 and 3). Cycle the tool.

Note: The tamper proof ratchet action will not release the tool until it

4. Remove the crimped terminal. Inspect for proper crimp location, and check for insulation closure. Locator is adjustable up and down to keep terminals straight after crimping.
5. If the insulation part of the crimp needs to be adjusted, first loosen the M4 screw on the bottom tool jaw, then insert a 3/32 hex wrench (supplied) into the bottom of the lower die (See Figure 4). A clockwise (CW) rotation decreases insulation crimp while a counter-clockwise (CCW) rotation increases insulation crimp. After adjusting retighten the M4 screw.

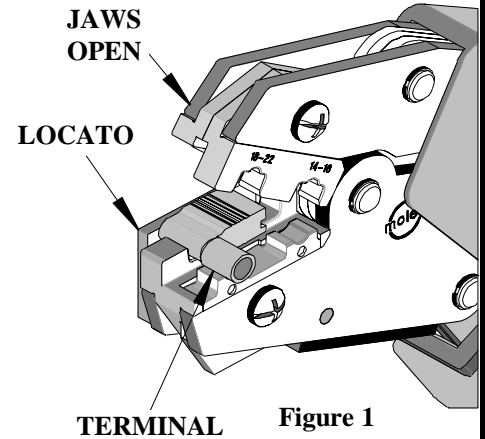

Figure 1

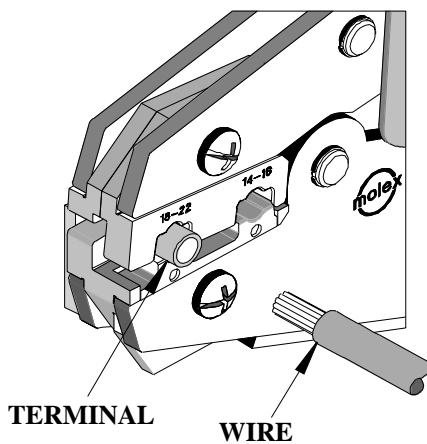

Figure 2

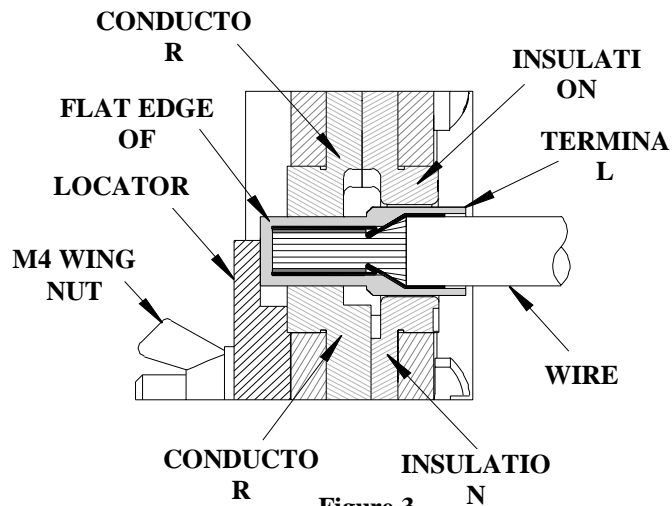

Figure 3

Maintenance

It is recommended that each operator of the tool be made aware of, and responsible for, the following maintenance steps:

1. Remove dust, moisture and other contaminants with a clean brush, or soft, lint-free cloth.
2. Do not use any abrasive materials that could damage the tool.

3. Make certain all pins; pivot points and bearing surfaces are protected with a thin coat of high quality machine oil. Do not oil excessively. The 64001-4300 (RHT-AFIFG) was engineered for durability, but like any fine piece of equipment it needs cleaning and lubrication for a maximum service life of trouble-free crimping. A light oil, such as 30 weight automotive oil used at the oil points shown in Figure 4, every 5,000 crimps or 3 months will significantly enhance the tool life and ensure a stable calibration.
4. When tool is not in use, keep the handles closed to prevent objects from becoming lodged in the crimping dies, and store the tool in a clean, dry area.

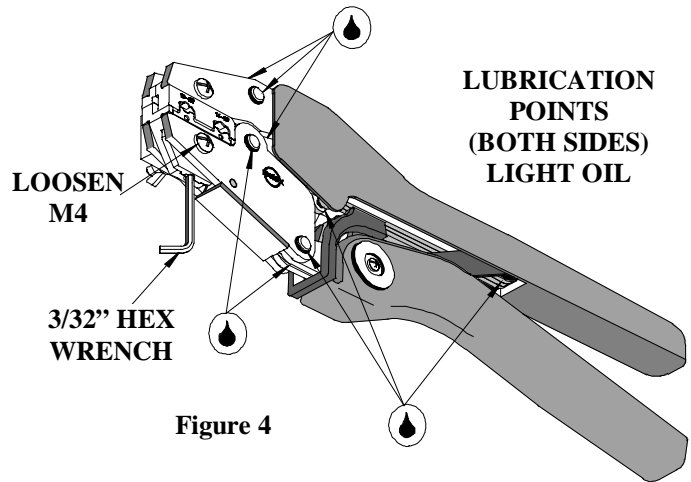

Figure 4

Miscrimps or Jams

Should this tool ever become stuck or jammed in a partially closed position, **Do Not force the handles open or closed.** The tool will open easily by lifting the ratchet release lever (See Fig.5).

How To Adjust Tool Preload (See Figure 5)

Over the life of the tool, it may be necessary to adjust tool handle preload force. Listed below are the steps required to adjust the crimping force of the hand tool to obtain proper crimp conditions:

1. Remove the screw and plastic cover washer. Note the setting wheel position.
2. Lift the setting wheel off the axle. Turn the eccentric axle with a screwdriver.
3. Turning the eccentric axle counter-clockwise (CCW) will increase handle force.
4. Replace the setting wheel to the axle, aligning the nearest notch in the setting wheel to the dowel pin.
5. Replace the plastic cover washer and screw.
6. Check the crimp specifications after tool handle preload force is adjusted.

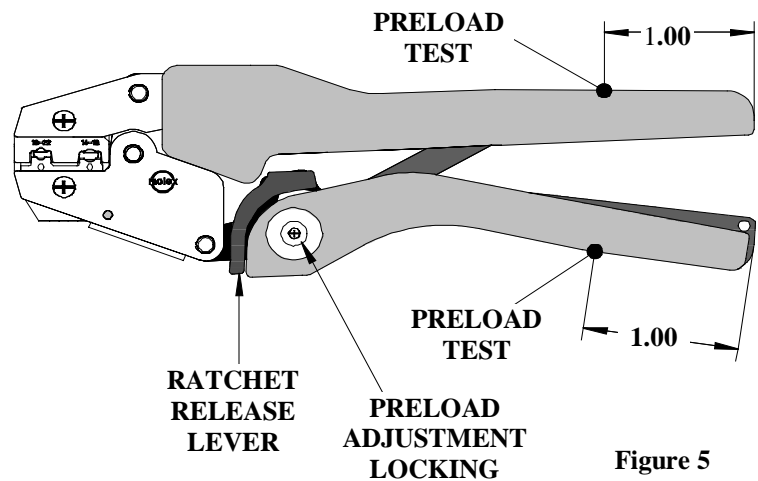
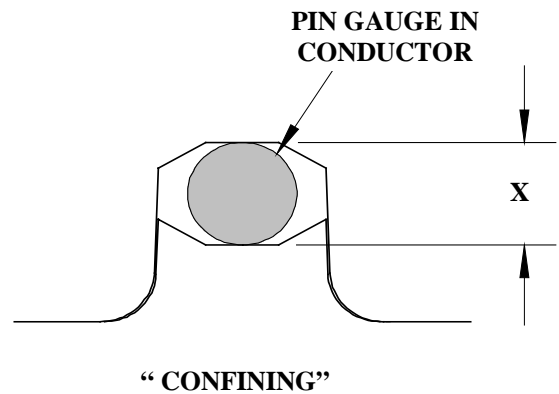

Figure 5

Tool Calibration

A Certificate of Calibration (see last page) was supplied with the tool. To recalibrate this tool, pin gauge measurements should be taken in each conductor nest and compared to this chart. The tool should be lubricated prior to recalibration to ensure consistent measurements. Handle preload is factory set to 25-45 LBS. See How to Adjust Tool Preload, (See Figure 5) to recalibrate.



Nest Color Code	Wire Range		“X” Dimension Conductor Crimp			Crimp Inspection Marking
	AWG	mm ²	Mean	Go	No Go	
Red	18 - 22	0.80 – 0.35	.075	.071	.079	---
Blue	14 - 16	2.00 – 1.30	.088	.084	.092	---

Warranty

This tool is for electrical terminal crimping purposes only. This tool is made of the best quality materials. All vital components are long life tested. All tools are warranted to be free of manufacturing defects for a period of 30 days. Should such a defect occur, we will repair or exchange the tool free of charge. This repair or exchange will not be applicable to altered, misused or damaged tools. This tool is designed for hand use only. Any clamping, fixturing, or use of handle extensions voids this warranty.

Hand held crimping tools are intended for low volume, prototyping, or repair requirements only.

Caution: Repetitive use of this tool should be avoided.

PARTS LIST

Item	Order No.	Description	Quantity
	64001-4300	Hand Crimp Tool	(Fig.6)
1	64000-0076	Repair Kit (Springs, Pins and E-Rings)	1
2	63810-0000	Handle	1
3	64001-4375	Locator Assembly	1
4	64001-4370	Tooling Kit	1
Tooling Kit Only			
5	64001-4302	Conductor Punch	1
6	64001-4301	Conductor Anvil	1
7	64001-4304	Insulation Punch	1
8	64001-4303	Insulation Anvil	1
9	N/A	4 mm Dia. by 5.0 mm Lg. Roll Pins	2**
10	N/A	#10-32 by 5/16" Lg. Cup Pt. Set Screw	1**

** The following purchased parts are available from an Industrial supply company such as MSC (1-800-645-7270).

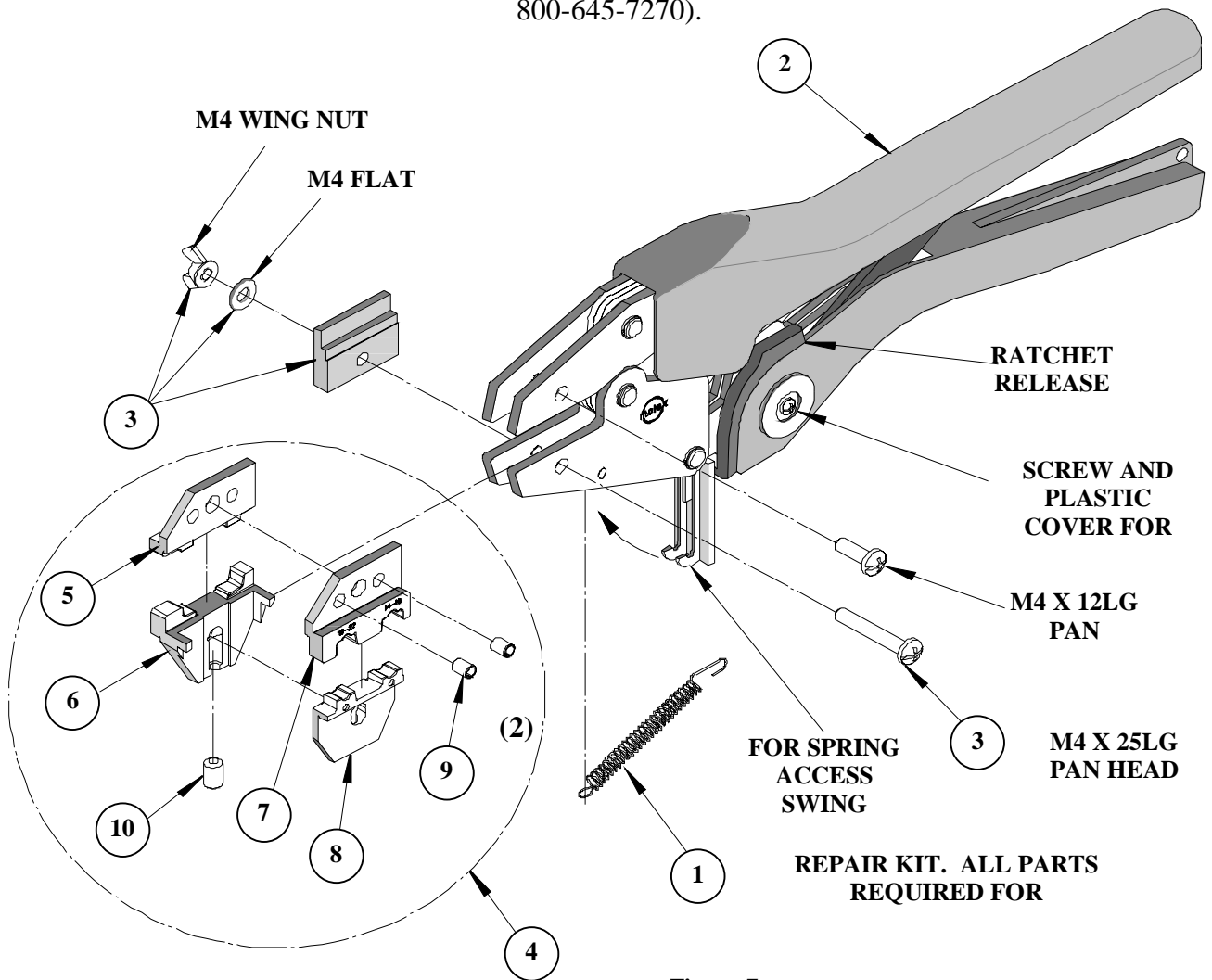
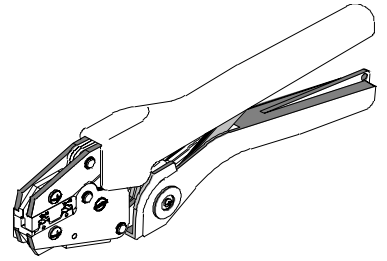

Figure 7



Certificate of Calibration

Tool Order Number _____

Tool Eng. Number _____

Tool Revision _____

Serial Number _____

Date of Manufacture _____

Handle Load Range at 1 inch from the Tips = _____

Actual = _____

Pin Gauge of Conductor Nest/Nests or Slug height if the nest is the "F" Crimp style.

Range Conductor Nest # 1 = _____ -- Actual = _____

Range Conductor Nest # 2 = _____ -- Actual = _____

Technician _____

Date of Calibration _____

Calibration should be done every 5,000 cycles or 3 months.

Tools should be lubricated during this operation.

Molex Application Tooling Group

1150 E. Diehl Road
Naperville, IL 60563
Tel: (630) 969-4550;
Fax: (630) 505-0049