

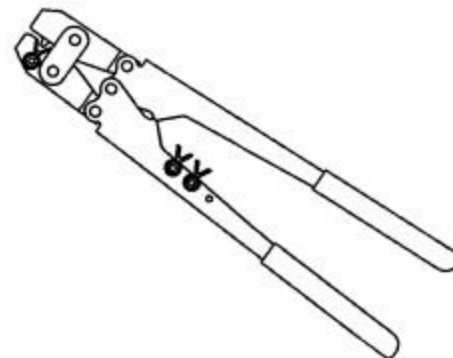

# Hand Crimp Tool Operating Instruction Sheet And Specifications Part No. 19284-0034 Eng. No. E-406



## FEATURES

- Heavy-duty cable crimping tool with hand held precision
- Perfect for maintenance and lower volume crimping
- 3 Interchangeable Die Inserts which are stored in the handle and covers the full wire range
- Long handles provide maximum mechanical advantage which reduces operator fatigue

## SCOPE

Eyelet Style Copper Lug Terminals 8-4/0 AWG.

### Testing

#### Mechanical

The tensile test, or pull test is, a means of evaluating the mechanical properties of the crimped connections. The following chart shows the UL Specifications for various wire sizes. The tensile strength is shown in pounds and indicates the minimum acceptable force to break or separate the terminal from the conductor.

Wire Size (AWG)	*UL - 486 A
8	90
6	100
4	140
2	180
1	200
1/0	250
2/0	300
3/0	350
4/0	450

\*UL - 486 A - Terminals (Copper conductors only)

The following is a partial list of the product part numbers and their specifications that this tool is designed to crimp. We will be adding to this list and an up to date copy is available on [www.molex.com](http://www.molex.com)

Wire Size: 8		8.50 mm <sup>2</sup>		Die Insert
Terminal No.	Terminal Eng No. (REF)	Wire Strip Length In	mm	
19221-0223	BCL-810-PL	.437	11.09	Insert A
19221-0224	BCL-814-PL	.437	11.09	Insert A
19221-0225	BCL-8516-PL	.437	11.09	Insert A
19221-0226	BCL-838-WP-PL	.437	11.09	Insert A
19221-0408	BCL-810	.437	11.09	Insert A
19221-0409	BCL-814	.437	11.09	Insert A
19221-0410	BCL-838-WP	.437	11.09	Insert A
19221-0411	BCL-8516	.437	11.09	Insert A
19221-0414	BCL-812-XWP-PL	.437	11.09	Insert A
19221-0415	BCL-812-XWP	.437	11.09	Insert A
19221-0481	BCL-838-XWP	.437	11.09	Insert A
19221-0482	BCL-8516-WP	.437	11.09	Insert A
19221-0483	BCL-8516-WP-PL	.437	11.09	Insert A
19221-0484	BCL-838-XWP-PL	.437	11.09	Insert A

Wire Size: 6		16.0 mm <sup>2</sup>		Die Insert
Terminal No.	Terminal Eng No. (REF)	Wire Strip Length In	mm	
19221-0227	BCL-614-WP-PL	.437	11.09	Insert A
19221-0228	BCL-6516-WP-PL	.437	11.09	Insert A
19221-0229	BCL-638-WP-PL	.437	11.09	Insert A
19221-0384	BCL-638-WP	.437	11.09	Insert A
19221-0406	BCL-614-WP	.437	11.09	Insert A
19221-0407	BCL-6516-WP	.437	11.09	Insert A
19221-0416	BCL-612-XWP-PL	.437	11.09	Insert A
19221-0417	BCL-612-XWP	.437	11.09	Insert A
19221-0424	BCL-610-PL	.437	11.09	Insert A
19221-0425	BCL-610	.437	11.09	Insert A
19221-0492	BCL-6561-PL	.437	11.09	Insert A
19221-0493	BCL-6561	.437	11.09	Insert A
19221-0494	BCL-614	.437	11.09	Insert A
19221-0495	BCL-6141-PL	.437	11.09	Insert A
19221-0568	BCL-638-XWP-PL	.437	11.09	Insert A
19221-0569	BCL-638-XWP	.437	11.09	Insert A

Wire Size: 4 25.0 mm <sup>2</sup>				
Terminal No.	Terminal Eng No. (REF)	Wire Strip Length		Die Insert
		In	mm	
19221-0230	BCL-414-PL	.500	12.70	Insert A
19221-0231	BCL-4516-RL	.500	12.70	Insert A
19221-0232	BCL-438-PL	.500	12.70	Insert A
19221-0383	BCL-438	.500	12.70	Insert A
19221-0404	BCL-414	.500	12.70	Insert A
19221-0405	BCL-4516	.500	12.70	Insert A
19221-0451	BCL-410	.500	12.70	Insert A
19221-0452	BCL-410-PL	.500	12.70	Insert A
19221-0453	BCL-412	.500	12.70	Insert A
19221-0454	BCL-412-PL	.500	12.70	Insert A
19221-0456	BCL-438-WP-PL	.500	12.70	Insert A
19221-0457	BCL-438-WXP-PL	.500	12.70	Insert A
19221-0458	BCL-438-WP	.500	12.70	Insert A
19221-0459	BCL-438-WXP	.500	12.70	Insert A
19221-0460	BCL-4516-WP-RL	.500	12.70	Insert A
19221-0461	BCL-4516-WP	.500	12.70	Insert A

Wire Size: 2 35.0 mm <sup>2</sup>				
Terminal No.	Terminal Eng No. (REF)	Wire Strip Length		Die Insert
		In	mm	
19221-0233	BCL-2516-RL	.562	14.27	Insert C
19221-0235	BCL-238-PL	.562	14.27	Insert C
19221-0236	BCL-212-WP-PL	.562	14.27	Insert C
19221-0380	BCL-238	.562	14.27	Insert C
19221-0399	BCL-212-WP	.562	14.27	Insert C
19221-0400	BCL-2516	.562	14.27	Insert C
19221-0418	BCL-214-PL	.562	14.27	Insert C
19221-0419	BCL-214	.562	14.27	Insert C

Wire Size: 1 42.4 mm <sup>2</sup>				
Terminal No.	Terminal Eng No. (REF)	Wire Strip Length		Die Insert
		In	mm	
19221-0237	BCL-1516-RL	.625	15.87	Insert C
19221-0238	BCL-138-PL	.625	15.87	Insert C
19221-0239	BCL-112-PL	.625	15.87	Insert C
19221-0378	BCL-138	.625	15.87	Insert C
19221-0395	BCL-112	.625	15.87	Insert C
19221-0396	BCL-1516	.625	15.87	Insert C
19221-0420	BCL-114-PL	.625	15.87	Insert C
19221-0421	BCL-114	.625	15.87	Insert C

Wire Size: 1/0 50.0 mm <sup>2</sup>				
Terminal No.	Terminal Eng No. (REF)	Wire Strip Length		Die Insert
		In	mm	
19221-0240	BCL-10516-PL	.687	17.44	Insert B
19221-0241	BCL-1038-RL	.687	17.44	Insert B
19221-0242	BCL-1012-RL	.687	17.44	Insert B
19221-0377	BCL-1038	.687	17.44	Insert B
19221-0393	BCL-1012	.687	17.44	Insert B
19221-0394	BCL-10516	.687	17.44	Insert B
19221-0422	BCL-1014-RL	.687	17.44	Insert B
19221-0423	BCL-1014	.687	17.44	Insert B
19221-0436	BCL-1012-WP-RL	.687	17.44	Insert B
19221-0437	BCL-1012-WP	.687	17.44	Insert B
19221-0440	BCL-1038-WP-RL	.687	17.44	Insert B
19221-0441	BCL-1038-WP	.687	17.44	Insert B

Wire Size: 2/0 70.0 mm <sup>2</sup>				
Terminal No.	Terminal Eng No. (REF)	Wire Strip Length		Die Insert
		In	mm	
19221-0234	BCL-2014-RL	.687	17.44	Insert B
19221-0243	BCL-20516-PL	.687	17.44	Insert B
19221-0244	BCL-2038-RL	.687	17.44	Insert B
19221-0245	BCL-2012-RL	.687	17.44	Insert B
19221-0249	BCL-2014	.687	17.44	Insert B
19221-0379	BCL-2038	.687	17.44	Insert B
19221-0397	BCL-2012	.687	17.44	Insert B
19221-0398	BCL-20516	.687	17.44	Insert B

Wire Size: 3/0 95.0 mm <sup>2</sup>				
Terminal No.	Terminal Eng No. (REF)	Wire Strip Length		Die Insert
		In	mm	
19221-0246	BCL-30516-PL	.750	19.05	No Insert
19221-0247	BCL-3038-RL	.750	19.05	No Insert
19221-0248	BCL-3012-RL	.750	19.05	No Insert
19221-0381	BCL-3038	.750	19.05	No Insert
19221-0401	BCL-3012	.750	19.05	No Insert
19221-0402	BCL-30516	.750	19.05	No Insert
19221-0478	BCL-3014	.750	19.05	No Insert
19221-0570	BCL-3014-RL	.750	19.05	No Insert

Wire Size: 4/0 120.0 mm <sup>2</sup>				
Terminal No.	Terminal Eng No. (REF)	Wire Strip Length		Die Insert
		In	mm	
19221-0250	BCL-4038-RL	.812	20.62	No Insert
19221-0251	BCL-4012-RL	.812	20.62	No Insert
19221-0371	BCL-4038-PL (.625)	.812	20.62	No Insert
19221-0372	BCL-4012-PL (.625)	.812	20.62	No Insert
19221-0374	BCL-4038 (.625)	.812	20.62	No Insert
19221-0375	BCL-4012 (.625)	.812	20.62	No Insert
19221-0382	BCL-4038	.812	20.62	No Insert
19221-0403	BCL-4012	.812	20.62	No Insert
19221-0412	BCL-40516-PL	.812	20.62	No Insert
19221-0413	BCL-40516	.812	20.62	No Insert
19221-0502	BCL-40516 (.625)	.812	20.62	No Insert
19221-0503	BCL-40516-PL (.625)	.812	20.62	No Insert

## INTRODUCTION

Hand Crimp Tool 19284-0034 (E-406) is used to crimp heavy-duty copper lug terminals onto the wire sizes given in the charts 1 and 2.

## DESCRIPTION

The tool consists of jaws, handles, and three interchangeable die inserts. Each die insert is marked with an alphabetic letter to correspond with the wire size being used. See terminal part number for correct insert.

**Note:** On some standard and minimum gauge cables, re-crimping the assembly with the next smaller insert may be advisable for maximum circuit efficiency

## OPERATION

### Crimping Terminals

1. Strip the wire to the dimension given in the preceding terminal lists.
2. Install the proper die insert onto the jaw. The three interchangeable die inserts are changed by removing the holding screw on the handle and installing the proper die insert into the jaws of the tool.
3. Insert the properly stripped wire into the terminal barrel.
4. Center the terminal barrel with the wire in the proper die insert. Make sure that the pad or bottom side of the terminal barrel faces the tool indenter.
5. Now close the crimp tool handles completely and release. Open the handles and remove the crimped terminal.
6. Inspect the product for a quality crimp.

Hand held crimping tools are intended for low volume, prototyping, or repair requirements only.

**Caution:** Repetitive use of this tool should be avoided.

### PARTS LIST

Item	Order No	Description	Quantity
1	19284-0034	Hand Crimp Tool	(Fig. 2)

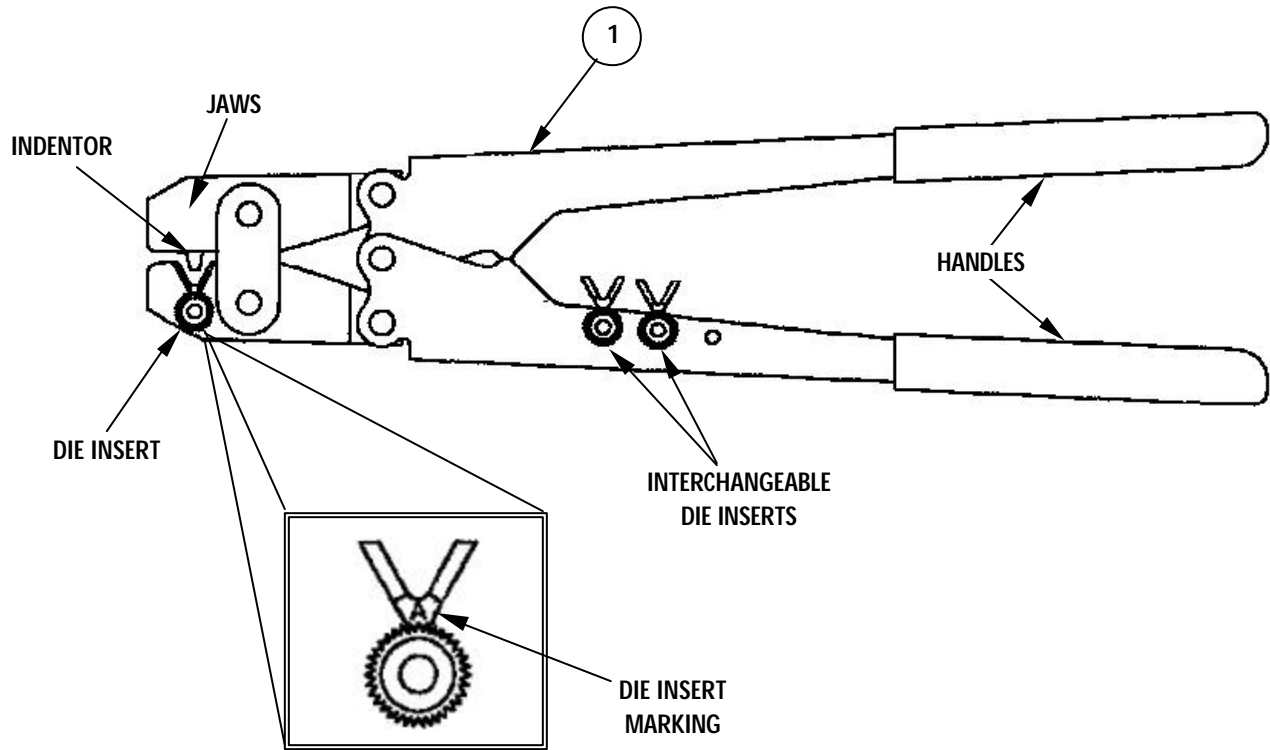

Figure 2

### Molex Application Tooling Group

1150 E. Diehl Road  
Naperville, IL 60563  
Tel: (630) 969-4550  
Fax: (630) 505-0049